

Configuring Gain with the THAT1510 & THAT1512

THAT Corporation's 1510 and 1512 are low noise, wide bandwidth microphone preamplifiers available in several different industry-standard packages. They allow designers to upgrade existing designs to take advantage of the superior performance of these new ICs. Both parts include on-board laser-trimmed resistors which allow differential gain to be set with a single external resistor. They differ from each other primarily in their internal gain structure, and their resulting noise performance.

The 1510 is a pin-for-pin, drop-in replacement for the Analog Devices SSM2019, and the now discontinued SSM2017, as well as the Texas Instruments INA217 audio preamplifiers. The 1510 noise and gain characteristics are equal to or better than those of these other parts, but the 1510 also improves on their distortion, bandwidth, and slew rate.

The 1512 is also a pin-for-pin replacement for the SSM2019/2017 and INA217, but due to its different gain structure, produces significantly lower noise at low gains and requires different external resistors to reach the same gain. Neither the 1510 nor the 1512 duplicates the front-end output terminals available on the TI INA163, but in instances when these outputs are not used, which is often true in audio applications, the 1512 can improve significantly on the INA163 noise performance (as well as on distortion, bandwidth, and slew rate) while producing a similar gain characteristic without other circuit modifications. It is possible to gain the noise advantages of the 1512 in substitution for the SSM2019/2017 and the INA217, but the resulting gain characteristics may be different enough to require other circuit modifications for some applications.

This design note is intended to offer some guidance on gain control to designers who are considering the 1510 or 1512, first for new designs, but also for replacements in existing circuits.

Controlling Gain

As shown in Figure 1, the 1510 and 1512 use a three-amplifier instrumentation amplifier (IA) topology. This configuration has the advantage of not amplifying common mode voltages as it amplifies signal, and as such, one can achieve excellent common mode rejection ratios (CMRR) that increase with the gain setting.

Additionally, the input stage of these parts uses an unconventional arrangement. The input amplifiers are configured to provide current feedback via resistors R_A and R_B to the emitters of the input transistors. These nodes are brought out to pins R_{G1} and R_{G2} . This allows the differential gain of the input section to be controlled by the external resistor R_G .

In order to reduce input voltage noise at low gains, the configuration of the 1512 differs from that of the 1510. The 1512 output stage has 6 dB less gain than that of the 1510. This leads to different gain equations for the two parts as follows.

$$\text{For the 1510: } A_V = 1 + \frac{10k\Omega}{R_G}, \text{ or } R_G = \frac{10k\Omega}{A_V - 1}.$$

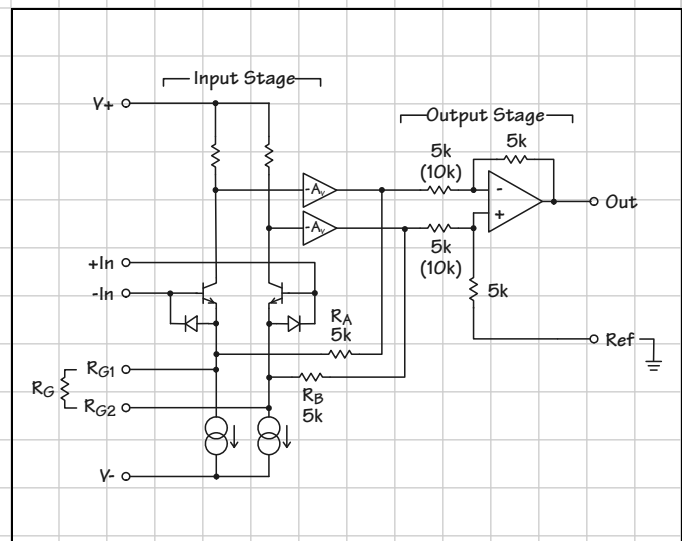

Figure 1. 1510/1512 Equivalent Circuit
(THAT1512 values shown in parentheses).

R_G	1510 Gain	1512 Gain
∞	0.0 dB	-6.0 dB
10 k Ω	+6.0 dB	0 dB
5 k Ω	+9.5 dB	+3.5 dB
1 k Ω	+20.8 dB	+14.8 dB
500 Ω	+26.4 dB	+20.4 dB
100 Ω	+40.1 dB	+34.1 dB
50 Ω	+46.1 dB	+40.0 dB
10 Ω	+60.0 dB	+54.0 dB
5 Ω	+66.0 dB	+60.0 dB

Table 1. Gain (rounded to the nearest 0.1dB) vs R_G for the 1510 and 1512.

Gain	1510 R_G	1512 R_G
-6 dB	Not possible	∞
0 dB	∞	10,000 Ω
+6 dB	10,048 Ω	3,344 Ω
+10 dB	4,625 Ω	1,878 Ω
+20 dB	1,111 Ω	526 Ω
+30 dB	327 Ω	161 Ω
+40 dB	101 Ω	50 Ω
+50 dB	32 Ω	16 Ω
+60 dB	10 Ω	5 Ω

Table 2. R_G (rounded to the nearest 1 Ω) vs Gain for the 1510 and 1512.

And, for the 1512: $A_V = 0.5 + \frac{5 \text{ k}\Omega}{R_G}$, or $R_G = \frac{5 \text{ k}\Omega}{A_V - 0.5}$; where A_V is the voltage gain, and R_G is in ohms.

The gain equations for the 1510 are identical to those for the SSM2017, SSM2019, and the INA217. This makes the 1510 convenient for drop-in replacement of these parts, offering a true second source with improved performance, and without requiring any redesign effort.

The gain equations for the 1512 are unique. Because of this, existing circuits may require some adjustment to substitute the 1512 for a 1510 or other manufacturers' preamp ICs.

Table 1 compares the gain of the 1510 with that of the 1512 for various values of R_G , while Table 2 shows R_G for various desired gains for both parts.

Basic Potentiometer-Based Variable Gain Control

Figure 2 shows a simplified application circuit for the 1510 and 1512 using a potentiometer to control gain. This circuit, and all the others shown in this design note, focuses on gain control to the exclusion of other necessary features. For example, it does not show the input RFI protection, phantom power and associated fault protection, input ac-coupling, or power supply bypassing essential to implement a mic preamp with ICs available on the

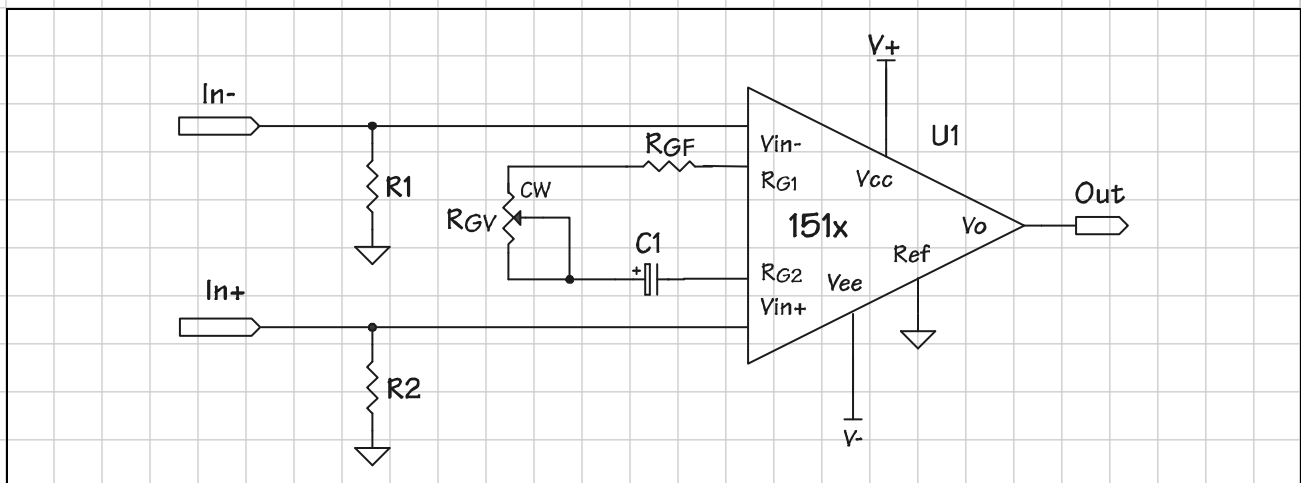

Figure 2. Simplified application circuit for the 1510/1512

market today. For complete information on circuit configurations for these ICs, see THAT's 1510/1512 data sheet.

Figure 3 shows how the decibel gain of the circuit of Figure 2 varies with pot rotation using a 1510 and various 10 kΩ pots for R_{GV} . The pots are all reverse audio (log) taper, using a two-segment piece-wise linear approximation to the log function; the tapers vary from 2.5% to 20%. The curves assume negligible wiper- and end-resistance for R_{GV} . R_{GF} is 10 Ω. R_{GF} limits the minimum resistance between R_{G1} and R_{G2} to 10 Ω, which limits the maximum gain to ~ 60 dB. R_{GV} , at 10 k, sets the maximum resistance between R_{G1} and R_{G2} to ~ 10 k, which limits minimum gain to ~ 6 dB for the 1510.

The 2.5% pot may look the most nonlinear on the plot, but in actuality, it is the best fit for a straight line approximation between 6 dB and 60 dB. With the 20% taper pot, the last 30 degrees of rotation results in over a 30 dB change in gain from ~28 dB to 60dB, whereas the 2.5% taper has only a 15 dB variation in gain (from ~45 dB to 60 dB) over this same angle. This makes settings much less sensitive at high gains.

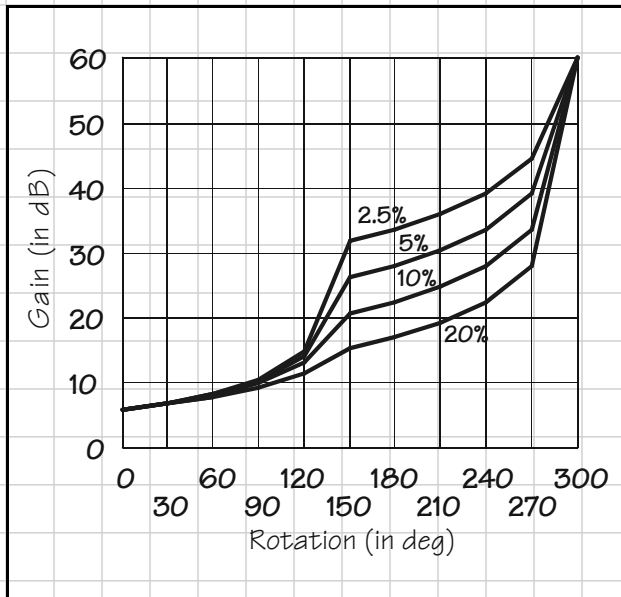

Figure 3. Gain trajectories for the circuit of Fig. 2, 1510 with various pot tapers, $R_{GV}=10k\Omega$, $R_{GF}=10\Omega$.

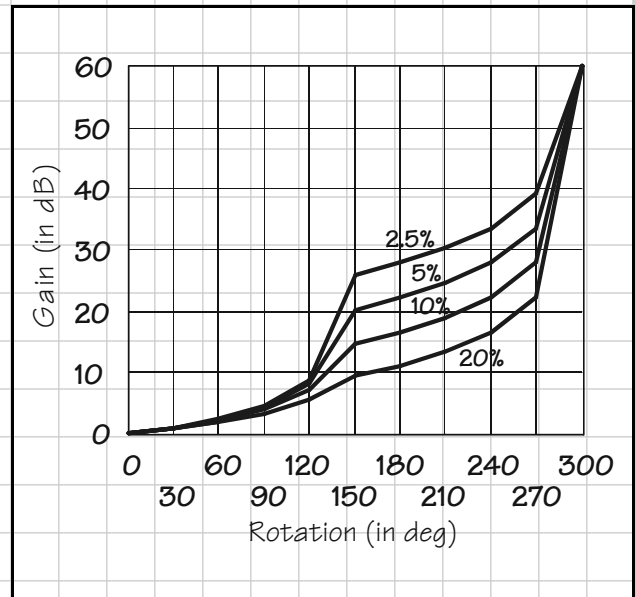

Figure 4. Gain trajectories for the circuit of Fig. 2, 1512 with various pot tapers, $R_{GV}=10k\Omega$, $R_{GF}=10\Omega$.

Figure 4 shows the same family of curves, but for the 1512. In this case, R_{GV} remains 10 kΩ, but R_{GF} is 5 Ω; for the 1512, this limits maximum gain to approximately 60 dB. Note that with the 10 kΩ pot, the 1512 reaches a minimum of 0 dB gain. Also, the wider gain range increases the sensitivity of gain change vs. rotation in the last 30 degrees of rotation (at higher gains).

Note that the 1512 will produce identical curves of gain vs. pot setting as those of Figure 3 if R_{GV} were 5 kΩ, and R_{GF} were 5 Ω.

SSM2017 / SSM2019 / INA217 to 1510

The 1510 is a direct replacement for the SSM2017, SSM2019, and INA217. No changes are required in existing circuits to take advantage of the improved distortion, bandwidth, and (in some cases) noise performance of the 1510 compared to these other parts.

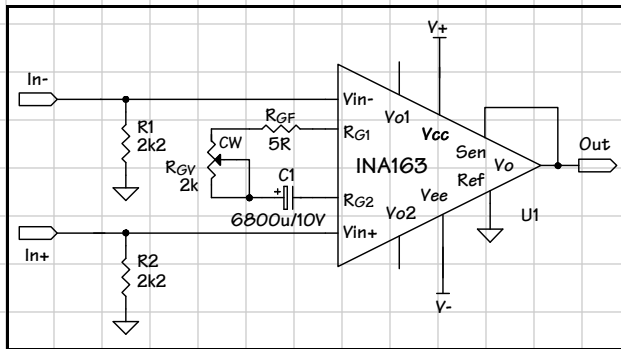

Figure 5. Example application circuit for the INA163, +12 ~+60 dB gain.

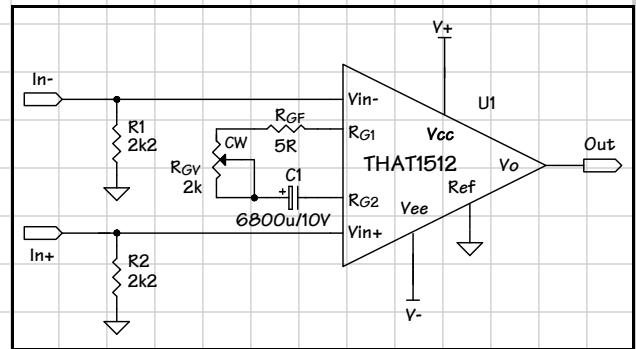

Figure 6. Substituting a 1512 for an INA163 in the circuit of Figure 5.

INA163 to 1512 - Without Any Circuit Changes

While the 1512 and the INA163 have different gain equations, for many applications the 1512 may be directly substituted for the INA163. In such cases, noise at low gains can be significantly improved, and the characteristic of gain vs. pot rotation is only slightly changed.

With this substitution, noise at high gain will be nearly identical, but noise at minimum gain will improve for the 1512 compared to the INA163.

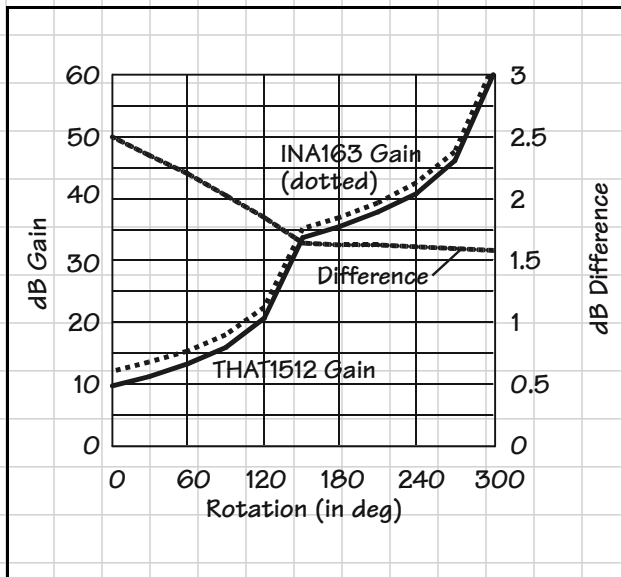

Figure 7. Gain vs. Pot Rotation for the circuit of Figure 5 compared to Figure 6.

The gain equations for the INA163 are:

$$A_V = 1 + \frac{6k\Omega}{R_G}, \text{ or } R_G = \frac{6k\Omega}{A_V - 1}, \text{ which are similar to those for the THAT1512.}$$

Figure 5 shows an example application circuit for the INA163. R_{GV} is a 2 k Ω , 5% reverse audio taper pot (e.g., the Alps "Rev. D" taper). R_{GF} is 5 Ω . With these resistances, gain varies from +12 to +62 dB. C_1 , at 6800 uF, avoids changes in dc output offset with gain. Note that V_{O1} and V_{O2} (the input stage outputs at pins 1 and 14, respectively), are not connected.

As shown in Figure 6, the 1512 may be substituted directly for the INA163 in this circuit. Figure 7 shows the gain trajectories of these two circuits along with the difference in gain that results from this direct substitution. At low gains there is about 2.5 dB of error, and at higher gains, the error drops to about 1.5 dB.

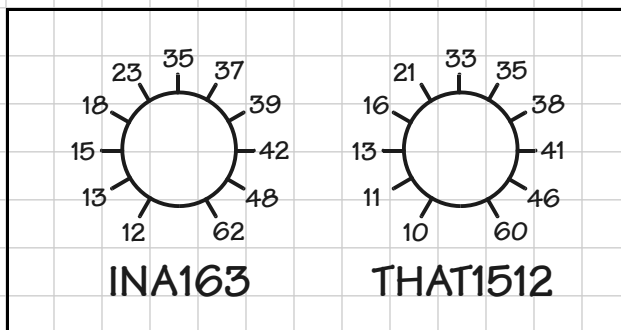

Figure 8. Theoretical front panel scales for INA163 (Figure 5) and 1512 (Figure 6).

Figure 8 shows the theoretical front panel scaling for these two circuits. The primary difference between the two gain trajectories is a relatively constant ~2 dB. If this error is unacceptable, it could be adjusted by changing the gain of a subsequent stage.

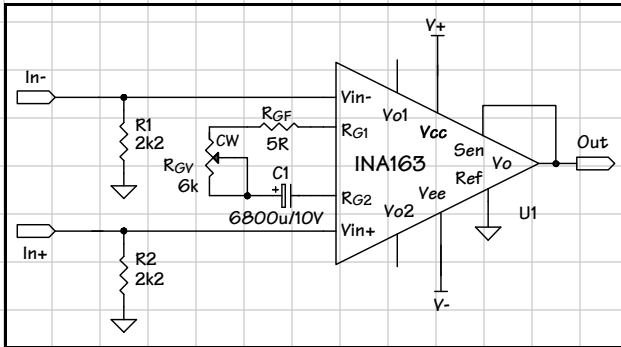

Figure 9. INA163 circuit for +6 ~+60 dB gain.

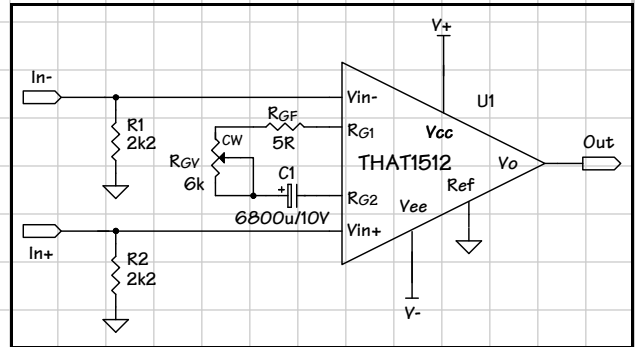

Figure 10. Substituting a 1512 for the INA163 in Figure 9.

Figure 9 shows an INA163 configured for minimum gain of +6 dB rather than +12 as shown in Figure 5. Figure 10 shows the same circuit with a 1512 directly substituted. Figure 11 shows the gain trajectories of these two circuits, while Figure 12 shows the front panel scaling for each circuit.

INA163 to 1512 - Optimized Circuitry

In some cases, designers may feel that the gain trajectory changes with the above circuits are unacceptable despite the small size of the gain differences. By changing to a more flexible topology it is possible to keep the gain trajectories closer by changing some passive components depending on which IC is used. The approach shown does not require any change in the pot.

Figure 13 shows a circuit with minimum gain of +12 dB (like Figures 5 through 8) optimized for both the INA163 and the 1512. For the INA163, R_{GF} would be a 6 Ω resistor, and for the 1512, 5 Ω . This change adjusts maximum gain to the same point: 60 dB, for each part. R_{GV} is 2k Ω for both ICs. R_3 is 10 k Ω for the 1512 and omitted for the INA163. This change adjusts minimum gain to the same point: +12 dB.

Figure 14 shows the gain trajectories and differences in this new circuit configuration. Note that the maximum error in this configuration is less than 1.5 dB -- about equal to the minimum error in the previous arrangement. Figure 15 shows theoretical front panel scalings for this arrangement. Note that the markings are nearly identical between the INA163 and the 1512.

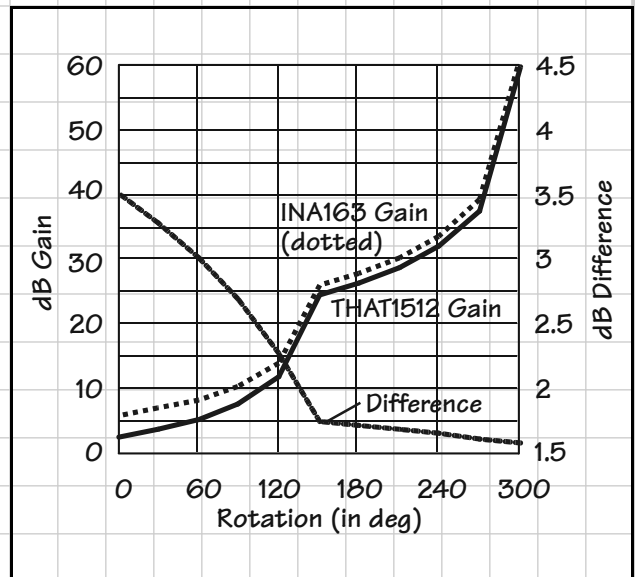

Figure 11. Gain vs. Pot Rotation for the circuit of Figure 9 compared to Figure 10.

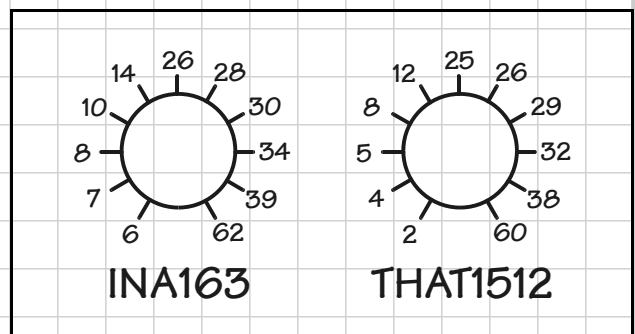

Figure 12. Theoretical front panel scales for INA163 (Figure 9) and 1512 (Figure 10).

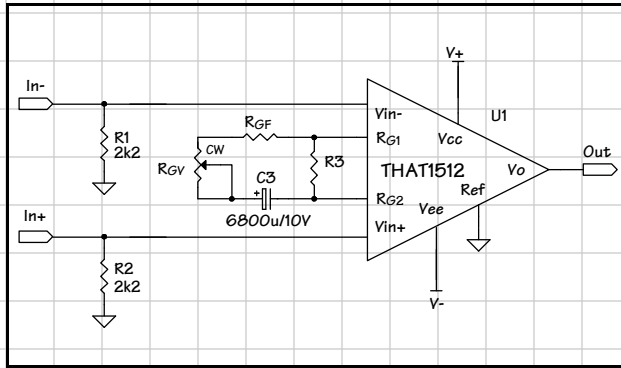

Figure 13. More versatile topology for 1512 to better support INA163. See text for values..

Minimum Gain of +6dB

To achieve a minimum gain of +6 dB simply change R_{GF} and R_3 . For the INA163, R_{GF} would be $6\ \Omega$, and for the 1512, $5\ \Omega$. R_{GF} changes to $6\ k\Omega$ for both ICs. R_3 is $6\ k\Omega$ for the 1512 and omitted for the INA163. Figure 16 shows the gain trajectories and differences for this configuration. Note that the error here swings from $\sim -0.5\ dB$ to $\sim +1.5\ dB$. Figure 17 shows theoretical front panel scalings for this arrangement. Again, the markings are nearly identical between the INA163 and the 1512.

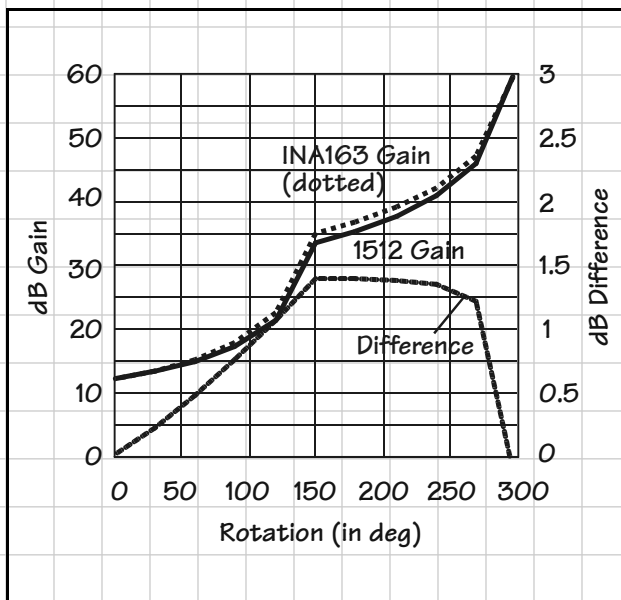

Figure 14. Gain vs. Pot Rotation for the (optimized) circuit of Figure 13 INA163 vs. 1512, 12 dB min gain.

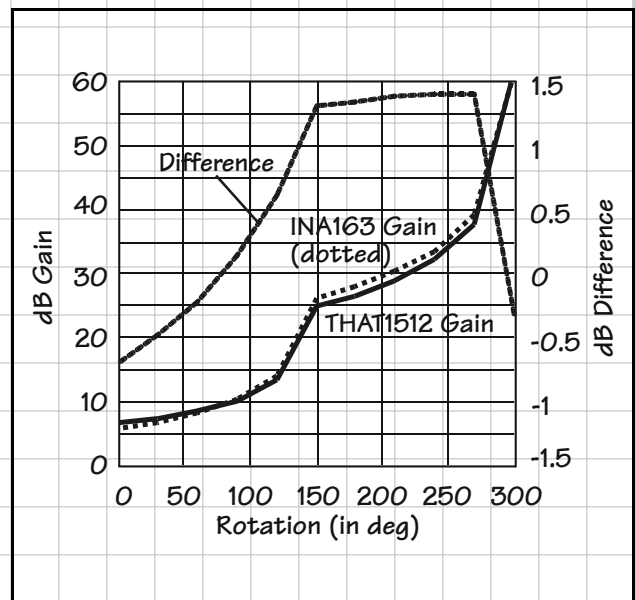

Figure 16. Gain vs. Pot Rotation for the (optimized) circuit of Figure 13 INA163 vs. 1512, 6 dB min gain.

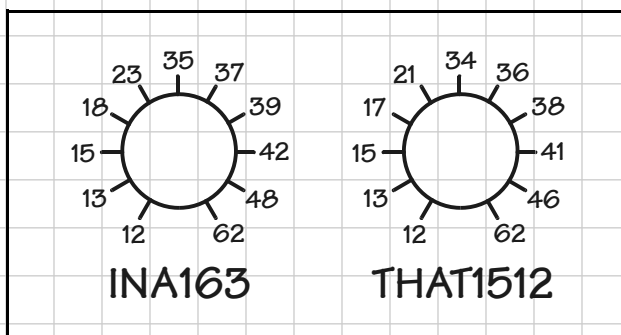

Figure 15. Theoretical front panel scales for the (optimized) circuit of Figure 13, INA163 vs. 1512, 12 dB min gain.

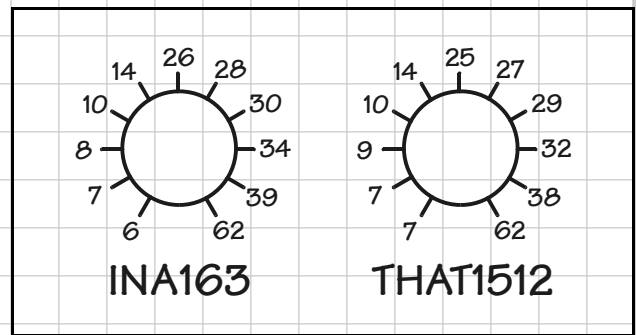

Figure 17. Theoretical front panel scales for the (optimized) circuit of Figure 13, INA163 vs. 1512, 6 dB min gain.

SSM2019/SSM2017/INA217 to 1512 - Without Any Circuit Changes

Within the available packages, the footprint of the 1512 is identical to that of the INA217, the SSM2019/2017, and the 1510; accordingly, the 1512 generally can be put into circuits designed for any of these devices. The advantages of replacing these devices with a 1512 include better bandwidth, higher slew rate, and lower distortion, as well as lower noise at low gains. That last advantage is not available when replacing the SSM2019/2017 with the 1510. Note that the 1510 noise, at low and high gain, is lower than that of the INA217.

Figure 18 shows a typical circuit based on the SSM2019 (or SSM2017, or INA217), configured for ~ +12dB minimum gain. Assuming a 5% reverse audio (log) taper pot, the graph in Figure 19 compares the gain trajectory of SSM2019 with that of the 1512 in the circuit of figure 18. Below ~50 dB of gain, the difference in gain is 5~6 dB, which may be acceptable in some applications.

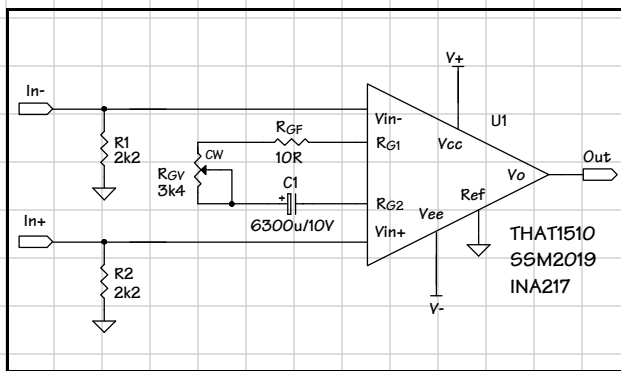

Figure 18. SSM2019 Circuit with minimum gain of +12dB.

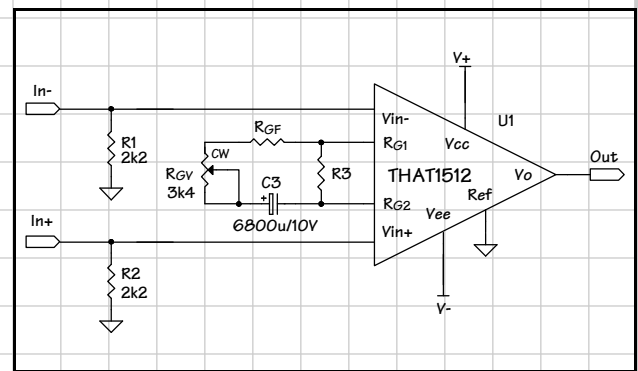

Figure 20. Optimized topology for 1512, to support the SSM2019, INA217, and THAT1510.

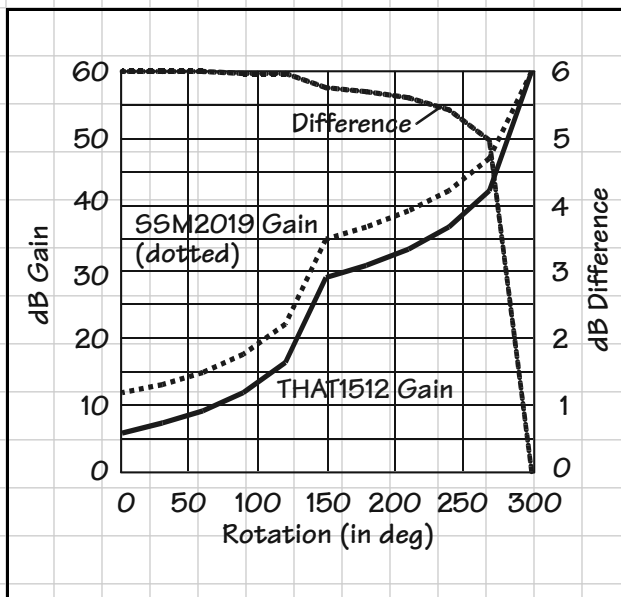

Figure 19. Gain vs. Pot Rotation for the circuit of Figure 18, 1510/SSM2019/INA217 vs. 1512, 12 dB gain.

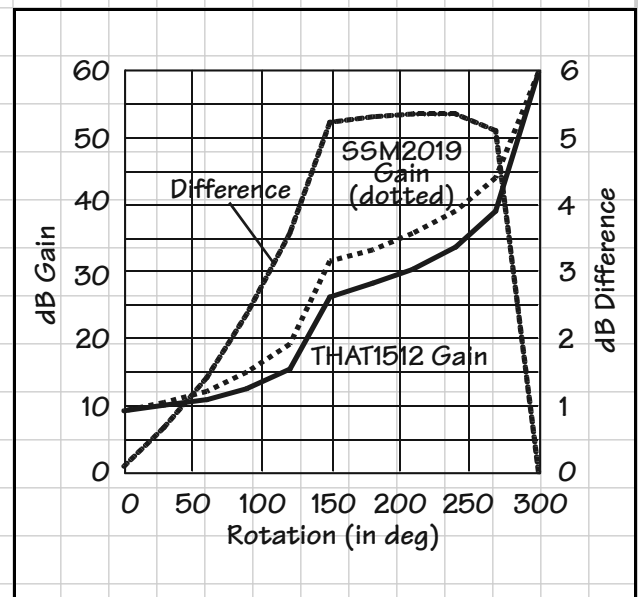

Figure 21. Gain vs. Pot Rotation for the (optimized) circuit of Figure 20, 1512 vs. SSM2019, ~ 12 dB min gain.

SSM2019/SSM2017/INA217 to 1512 - Optimized Circuitry

For those that find this degree of error unacceptable, there are several other approaches, though they all entail some degree of change to the circuit.

Consider the circuit in Figure 20. This circuit uses a paralleled resistor similar to that used in the optimized INA163 retrofit. Assuming gain range from +12 dB to +60 dB, the 1512 requires, $R_{GF} = 5 \Omega$ and $R_3 = 2.5 k\Omega$. The SSM2019, INA217, and 1510 require $R_{GF} = 10 \Omega$, while R_3 is omitted (open). R_{GV} is 3.4 k Ω in both cases. The resulting gain trajectory and difference between the two part types is shown in Figure 21. Using R_{GF} and R_3 , it is possible to force the differences at the endpoints to zero, though this will not minimize the average error.

Better results can be had by changing the value of the pot itself. Figure 22 shows a circuit with R_{GF} at 5 Ω and R_{GV} as a 2 k Ω , 5% reverse audio taper pot. These changes result in gain trajectory similar to that of Figure 18; +12 to +60 dB. See Figure 23 for the comparison. This approach is best for matching the gain trajectory of the SSM2017/2019 and

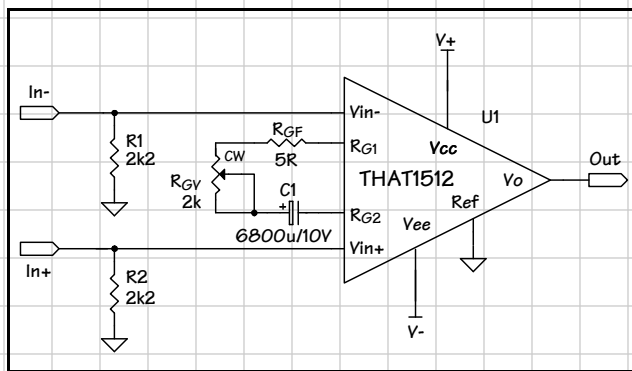

Figure 22. +12 dB min. gain with 1512, changing R_{GV} to match Figure 18.

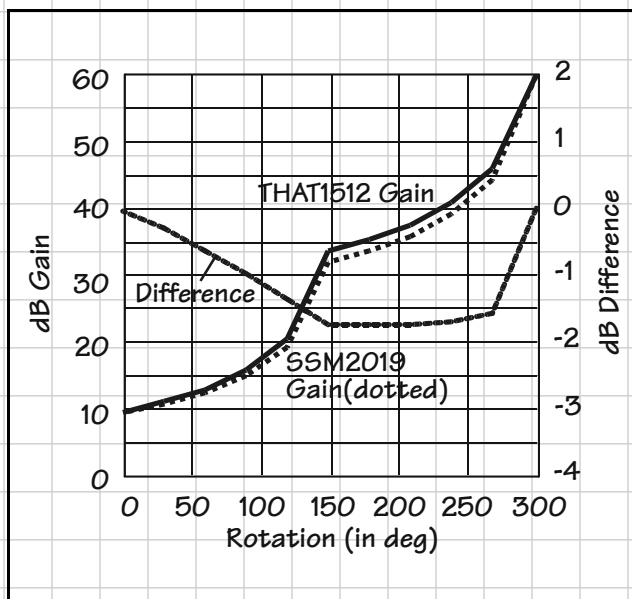

Figure 23. Gain vs. Pot Rotation for the circuit of Figure 22 compared to Figure 18, THAT1512 vs. SSM2019.

INA217 with a 1512. The result will be better bandwidth, higher slew rate, lower distortion, and lower noise at low gains without any compromise in gain trajectory or front panel calibration.

Further thoughts

We reiterate that all the circuits shown here are incomplete. They lack the input RFI protection, phantom power and associated fault protection, input ac-coupling, and power supply bypassing necessary to implement a mic preamp with these and other similar ICs. For complete information on circuit configurations for these ICs, see THAT's 1510/1512 data sheet.

We hope that the above notes and circuits will help point the way for designers to take advantage of the performance improvements available with THAT's 1510 and 1512 audio preamplifier ICs, while maintaining flexibility in sources of supply. Because of the wide range of variations possible with our and other makers' preamplifier ICs, we encourage designers to contact us directly to discuss your specific application and how to best configure your circuits to take full advantage of our ICs' great performance. You can reach us by e-mail at tech_support@thatcorp.com, by fax at +1(508)478-0990, by phone at +1(508)478-9200, or on the web at www.thatcorp.com. We look forward to discussing your application directly with you.