

APPLICATION NOTE

AN174

Applications for compandors SA570/571
SA571

1997 Aug 20

Philips Semiconductors



PHILIPS

Applications for companders NE570/571/SA571

AN174

APPLICATIONS

The following circuits will illustrate some of the wide variety of applications for the SA570.

BASIC EXPANDOR

Figure 1 shows how the circuit would be hooked up for use as an expander. Both the rectifier and ΔG cell inputs are tied to V_{IN} so that the gain is proportional to the average value of (V_{IN}). Thus, when V_{IN} falls 6dB, the gain drops 6dB and the output drops 12dB. The exact expression for the gain is

$$\text{Gain exp.} = \left[\frac{2 R_3 V_{IN} (\text{avg})}{R_1 R_2 I_B} \right]^2$$

$$I_B = 140\mu\text{A}$$

The maximum input that can be handled by the circuit in Figure 1 is a peak of 3V. The rectifier input current can be as large as $I = 3V/R_1 = 3V/10k = 300\mu\text{A}$. The ΔG cell input current should be limited to $I = 2.8V/R_2 = 2.8V/20k = 140\mu\text{A}$. If it is necessary to handle larger input voltages than $0 \pm 2.8V$ peak, external resistors should be placed in series with R_1 and R_2 to limit the input current to the above values.

Figure 1 shows a pair of input capacitors C_{IN1} and C_{IN2} . It is now necessary to use both capacitors if low level tracking accuracy is not important. If R_1 and R_2 are tied together and share a common capacitor, a small current will flow between the ΔG cell summing node and the rectifier summing node due to offset

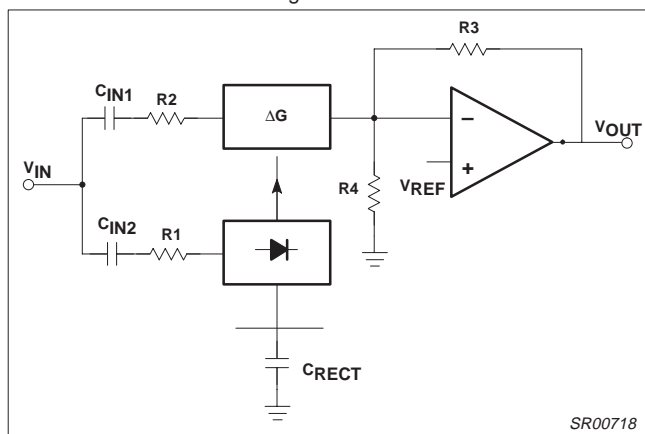

Figure 1. Basic Expander

voltages. This current will produce an error in the gain control signal at low levels, degrading tracking accuracy.

The output of the expander is biased up to 3V by the DC gain provided by R_3 , R_4 . The output will bias up to

$$V_{OUTDC} = 1 + \frac{R_3}{R_4} V_{REF}$$

For supply voltages higher than 6V, R_4 can be shunted with an external resistor to bias the output up to V_{CC} .

Note that it is possible to externally increase R_1 , R_2 , and R_3 , and to decrease R_3 and R_4 . This allows a great deal of flexibility in setting up system levels. If larger input signals are to be handled, R_1 and R_2 may be increased; if a larger output is required, R_3 may be

increased. To obtain the largest dynamic range out of this circuit, the rectifier input should always be as large as possible (subject to the $\pm 300\mu\text{A}$ peak current restriction).

BASIC COMPRESSOR

Figure 2 shows how to use the SA570/571 as a compressor. It functions as an expander in the feedback loop of an op amp. If the input rises 6dB, the output can rise only 3dB. The 3dB increase in output level produces a 3dB increase in gain in the ΔG cell, yielding a 6dB increase in feedback current to the summing node. Exact expression for gain is

$$\text{Gain comp.} = \left[\frac{R_1 R_2 I_B}{2 R_3 V_{IN} (\text{avg})} \right]^2$$

The same restrictions for the rectifier and ΔG cell maximum input current still hold, which place a limit on the maximum compressor output. As in the expander, the rectifier and ΔG cell inputs could be made common to save a capacitor, but low level tracking accuracy would suffer. Since there is no DC feedback path around the op amp through the ΔG cell, one must be provided externally. The pair of resistors R_{DC} and the capacitor C_{DC} must be provided. The op amp output will bias up to

$$V_{OUTDC} = \left(1 + \frac{R_{DC}}{R_4} \right) V_{REF}$$

For the largest dynamic range, the compressor output should be as large as possible so that the rectifier input is as large as possible (subject to the $\pm 300\mu\text{A}$ peak current restriction). If the input signal is small, a large output can be produced by reducing R_3 with the attendant decrease in input impedance, or by increasing R_1 or R_2 . It would be best to increase R_2 rather than R_1 so that the rectifier input current is not reduced.

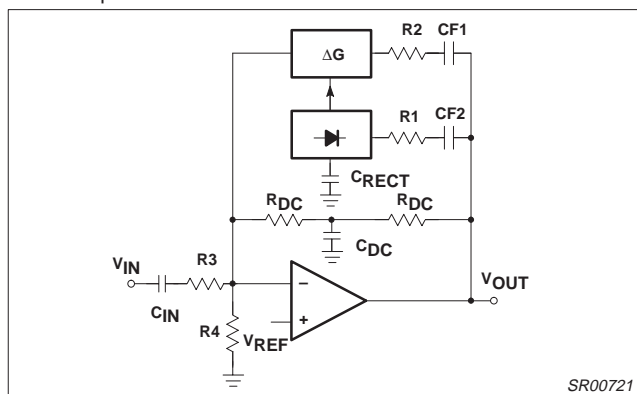

Figure 2. Basic Compressor

DISTORTION TRIM

Distortion can be produced by voltage offsets in the ΔG cell. The distortion is mainly even harmonics, and drops with decreasing input signal (input signal meaning the current into the ΔG cell). The THD trim terminal provides a means for trimming out the offset voltages and thus trimming out the distortion. The circuit shown in Figure 3 is suitable, as would be any other capable of delivering $\pm 30\mu\text{A}$ into 100Ω resistor tied to 1.8V.

Applications for companders NE570/571/SA571

AN174

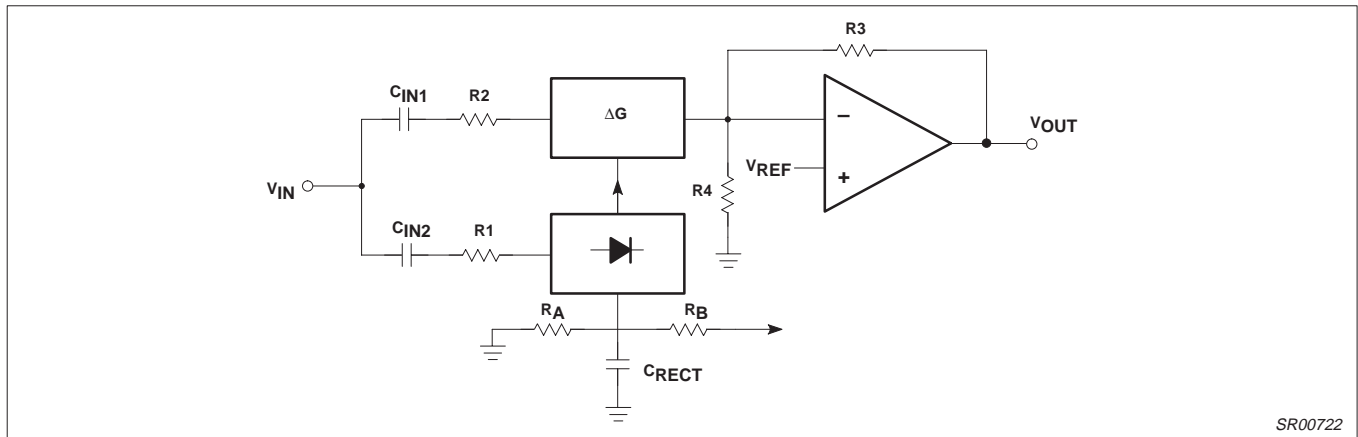

Figure 3. Expander With Low Level Mistracking

LOW LEVEL MISTRACKING

The compander will follow a 2-to-1 tracking ratio down to very low levels. The rectifier is responsible for errors in gain, and it is the rectifier input bias current of <100nA that produces errors at low levels. The magnitude signal level drops to a 1μA average, the bias current will produce a 10% or 1dB error in gain. This will occur at 42dB below the maximum input level.

at low level signals the result would be infinite compression. The bleed current through RA will be a function of temperature because of the two VBE drops, so the low level tracking will drift with temperature. If a negative supply is available, it would be desirable to tie RA to that, rather than ground, and to increase its value accordingly. The bleed current will then be less sensitive to the VBE temperature drift.

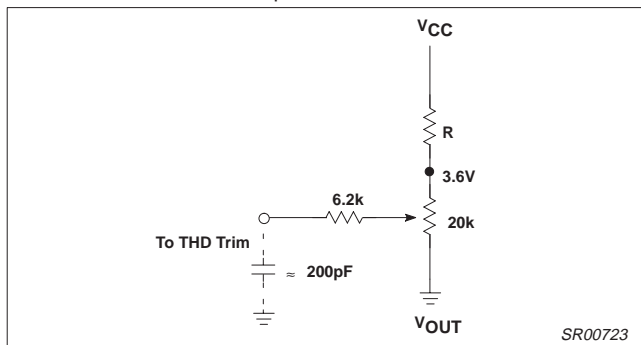

Figure 4. THD Trim Network

It is possible to deviate from the 2-to-1 transfer characteristic at low levels as shown in the circuit of Figure 4. Either RA or RB, (but not both), is required. The voltage on CRECT is 2×VBE plus VIN avg. For low level inputs VIN avg is negligible, so we can assume 1.3V as the bias on CRECT. If RA is placed from CRECT to AND we will bleed off a current I=1.3V/RA. If the rectifier average input current is less than this value, there will be no gain control input to the ΔG cell so that its gain will be zero and the expander output will be zero. As the input level is raised, the input current will exceed 1.3V/RA and the expander output will become active. For large input signals, RA will have little effect. The result of this is that we will deviate from the 2-to-1 expansion, present at high levels, to an infinite expansion at low levels where the output shuts off completely. Figure 5 shows some examples of tracking curves which can be obtained. Complementary curves would be obtained for a compressor, where

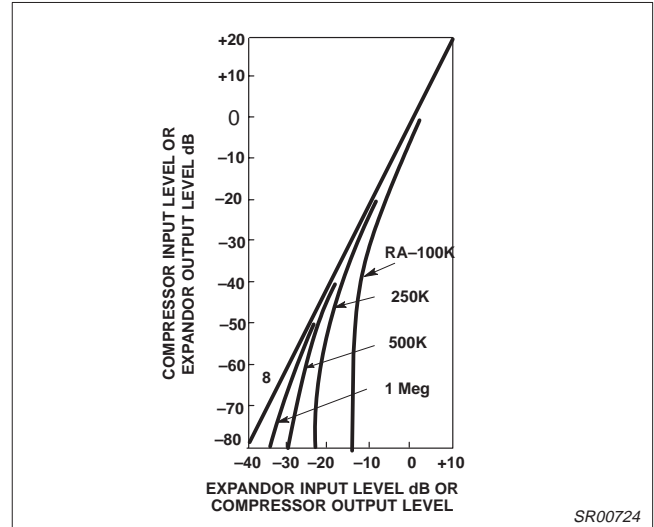

Figure 5. Mistracking With RA

RB will supply an extra current to the rectifier equal to (VCC-1.3V)RB. In this case, the expander transfer characteristic will deviate towards 1-to-1 at low levels. At low levels the expander gain will stop dropping and the expansion will cease. In a compressor, this would lead to a lack of compression at low levels. Figure 6 shows some typical transfer curves. An RB value of approximately 2.5M would trim the low level tracking so as to match the Bell system N2 trunk compander characteristic.

Applications for compandors NE570/571/SA571

AN174

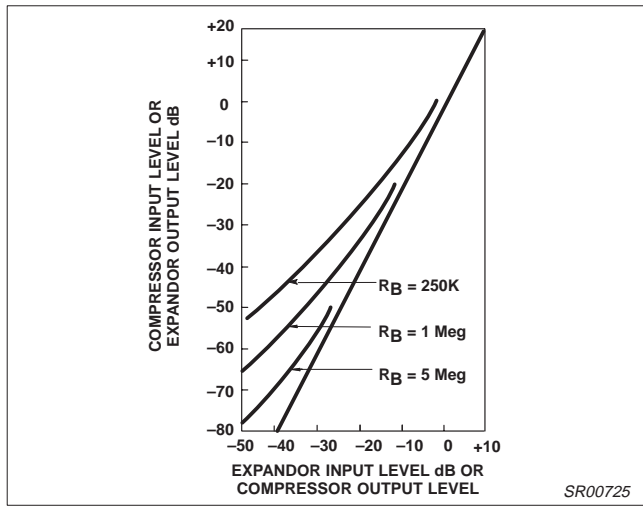

Figure 6. Mistracking With R_B

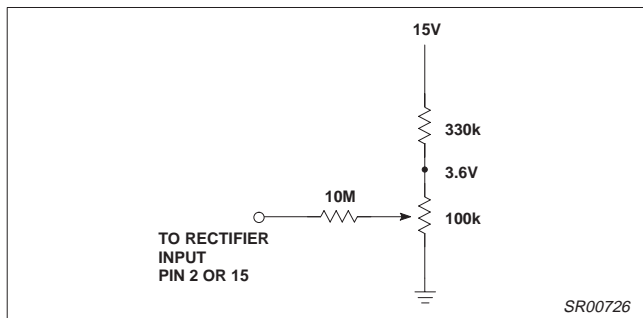

Figure 7. Rectifier Bias Current Compensation

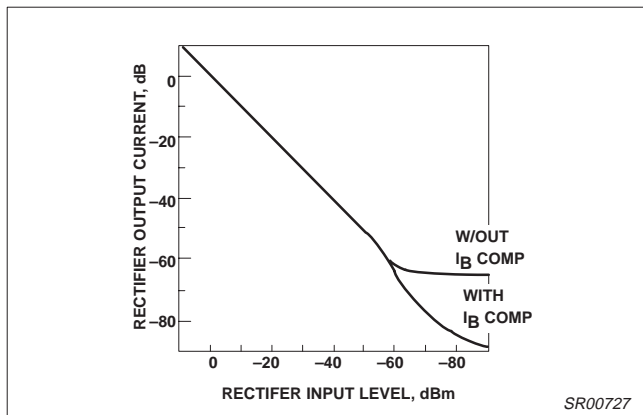

Figure 8. Rectifier Performance With Bias Current Compensation

RECTIFIER BIAS CURRENT CANCELLATION

The rectifier has an input bias current of between 50 and 100nA. This limits the dynamic range of the rectifier to about 60dB. It also limits the amount of attenuation of the ΔG cell. The rectifier dynamic range may be increased by about 20dB by the bias current trim network shown in Figure 7. Figure 8 shows the rectifier performance with and without bias current cancellation.

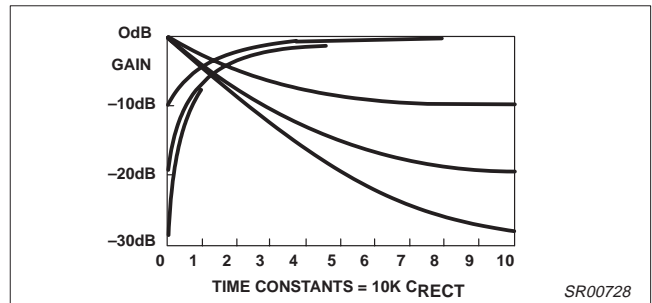

Figure 9. Gain vs Time Input Steps of ± 10 , ± 20 , ± 30 dB

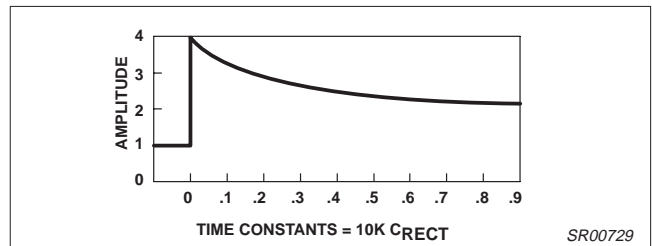

Figure 10. Compressor Attack Envelope $+12$ dB Step

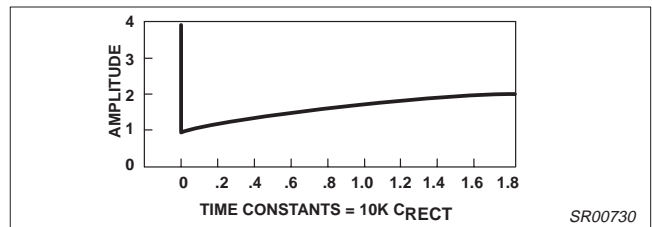

Figure 11. Compressor Release Envelope -12 dB Step

ATTACK AND DECAY TIME

The attack and decay times of the compandor are determined by the rectifier filter time constant $10k \times C_{RECT}$. Figure 9 shows how the gain will change when the input signal undergoes a 10, 20, or 30dB change in level.

The attack time is much faster than the decay, which is desirable in most applications. Figure 10 shows the compressor attack envelope for a $+12$ dB step in input level. The initial output level of 1 unit instantaneously rises to 4 units, and then starts to fall towards its final value of 2 units. The CCITT recommendation on attack and decay times for telephone system compandors defines the attack time as when the envelope has fallen to a level of 3 units, corresponding to $t=0.15$ in the figure. The CCITT recommends an attack time of 3 ± 2 ms, which suggests an RC product of 20ms. Figure 11 shows the compressor output envelope when the input level is suddenly reduced 12dB. The output, initially at a level of 4 units, drops 12dB to 1 unit and then rises to its final value of 2 units. The CCITT defines release time as when the output has risen to 1.5 units, and suggests a value of 13.5 ± 9 ms. This corresponds to $t=0.675$ in the figure, which again suggests a 20ms RC product. Since $R_1=10k$, the CCITT recommendations will be met if $C_{RECT}=2\mu F$.

There is a trade-off between fast response and low distortion. If a small C_{RECT} is used to get very fast attack and decay, some ripple

Applications for compandors NE570/571/SA571

AN174

will appear on the gain control line and produce distortion. As a rule, a $1\mu\text{F}$ C_{RECT} will produce 0.2% distortion at 1kHz. The distortion is inversely proportional to both frequency and capacitance. Thus, for telephone applications where $C_{\text{RECT}}=2\mu\text{F}$, the ripple would cause 0.1% distortion at 1kHz and 0.33% at 800Hz. The low frequency distortion generated by a compressor would be cancelled (or undistorted) by an expander, providing that they have the same value of C_{RECT} .

FAST ATTACK, SLOW RELEASE HARD LIMITER

The SA570/571 can be easily used to make an excellent limiter. Figure 12 shows a typical circuit which requires of an SA570/571, of an LM339 quad comparator, and a PNP transistor. For small signals, the ΔG cell is nearly off, and the circuit runs at unity gain as set by R_8 , R_7 . When the output signal tries to exceed a + or -1V peak, a comparator threshold is exceeded. The PNP is turned on and rapidly charges C_4 which activates the ΔG cell. Negative feedback through the ΔG cell reduces the gain and the output signal level. The attack time is set by the RC product of R_{18} and C_4 , and the release time is determined by C_4 and the internal rectifier resistor, which is 10k. The circuit shown attacks in less than 1ms and has a release time constant of 100ms. R_9 trickles about $0.7\mu\text{A}$

through the rectifier to prevent C_4 from becoming completely discharged. The gain cell is activated when the voltage on Pin 1 or 16 exceeds two diode drops. If C_4 were allowed to become completely discharged, there would be a slight delay before it is recharged to $>1.2\text{V}$ and activated limiting action.

A stereo limiter can be built out of 1 SA570/571, 1 LM339 and two PNP transistors. The resistor networks R_{12} , R_{13} and R_{14} , R_{15} , which set the limiting thresholds, could be common between channels. To gang the stereo channels together (limiting in one channel will produce a corresponding gain change in the second channel to maintain the balance of the stereo image), then Pins 1 and 16 should be jumpered together. The outputs of all 4 comparators may then be tied together, and only one PNP transistor and one capacitor C_4 need be used. The release time will then be the product $5k \times C_4$ since two channels are being supplied current from C_4 .

USE OF EXTERNAL OP AMP

The operational amplifiers in the SA570/571 are not adequate for some applications.

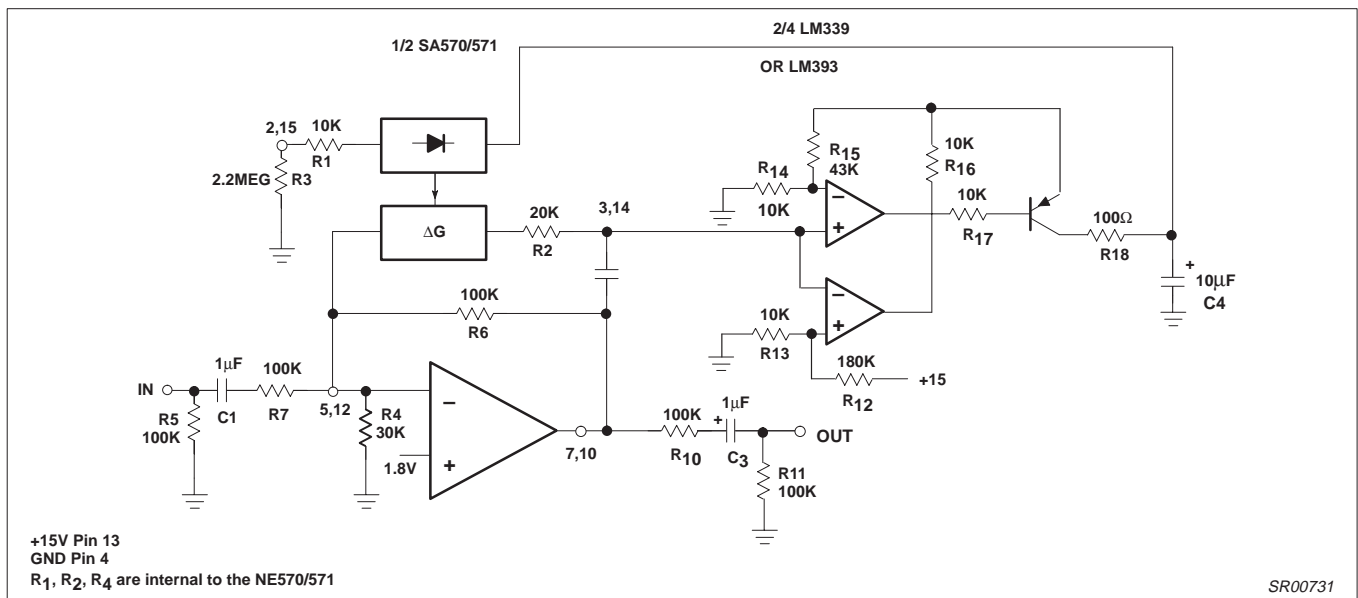

Figure 12. Fast Attack, Slow Release Hard Limiter

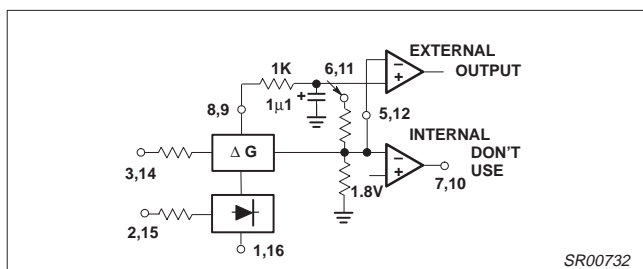

Figure 13. Use of External Op Amp

The slow rate, bandwidth, noise, and output drive capability can limit performance in many systems. For best performance, an external

op amp can be used. The external op amp may be powered by bipolar supplies for a larger output swing.

Figure 13 shows how an external op amp may be connected. The non-inverting input must be biased at about 1.8V. This is easily accomplished by tying it to either Pin 8 or 9, the THD trim pins, since these pins sit at 1.8V. An optional RC decoupling network is shown which will filter out the noise from the SA570/571 reference (typically about $10\mu\text{V}$ in 20kHz BW). The inverting input of the external op amp is tied to the inverting input of the internal op amp. The output of the external op amp is then used, with the internal op amp output left to float. If the external op amp is used single supply ($+V_{\text{CC}}$ and ground), it must have an input common-mode range down to less than 1.8V.

Applications for compandors NE570/571/SA571

AN174

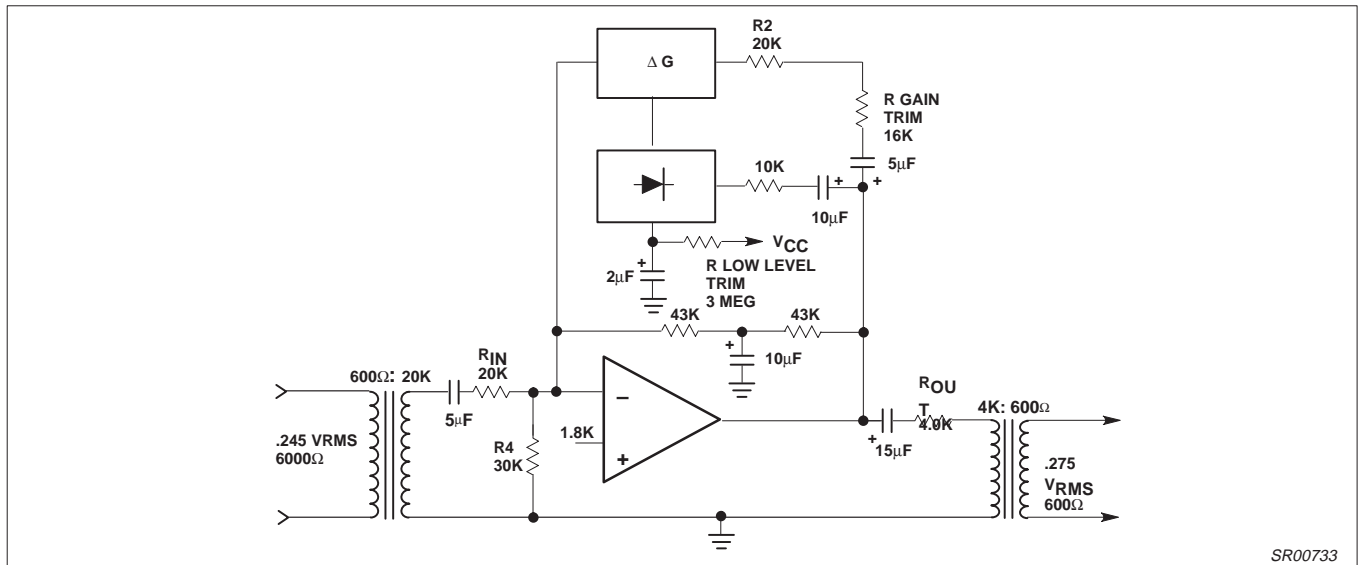

Figure 14. N2 Compressor

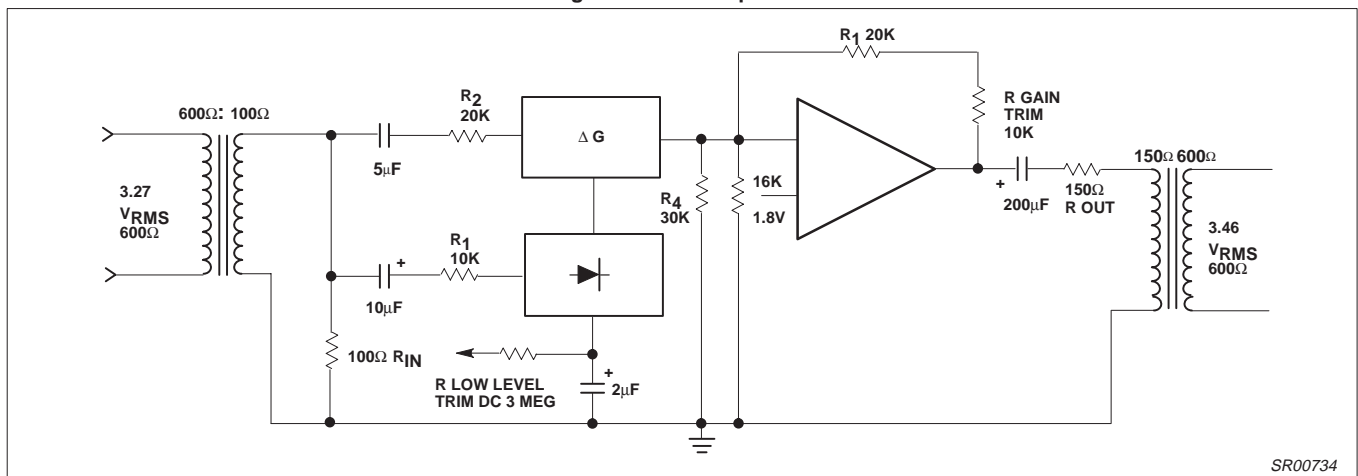

Figure 15. N2 Expander

N2 COMPANDOR

There are four primary considerations involved in the application of the SA570/571 in an N2 compandor. These are matching of input and output levels, accurate 600Ω input and output impedances, conformance to the Bell system low level tracking curve, and proper attack and release times.

Figure 14 shows the implementation of an N2 compressor. The input level of 0.245V_{RMS} is

stepped up to 1.41V_{RMS} by the 600Ω:20kΩ matching transformer. The 20k input resistor properly terminates the transformer. An internal 20kΩ resistor (R₃) is provided, but for accurate impedance termination an external resistor should be used. The output impedance is provided by the 4kΩ output resistor and the 4kΩ:600Ω output transformer.

The 0.275V_{RMS} output level requires a 1.4V op amp output level. This can be provided by increasing the value of R₂ with an external resistor, which can be selected to fine trim the gain. A rearrangement of the compressor gain equation (6) allows us to determine the value for R₂.

$$R_2 = \frac{\text{Gain}^2 \times 2 \times R_3 \times V_{IN \text{ avg}}}{R_1 \times I_B}$$

$$= \frac{1^2 \times 2 \times 20k \times 1.27}{10k \times 140\mu A}$$

$$= 36.3k$$

The external resistance required will thus be 36.3k–20k=16.3k.

The Bell-compatible low level tracking characteristic is provided by the low level trim resistor from C_{RECT} to V_{CC}. As shown in Figure 6, this will skew the system to a 1:1 transfer characteristic at low levels. The 2µF rectifier capacitor provides attack and release times of 3ms and 13.5ms, respectively, as shown in Figures 10 and 11. The R-C-R network around the op amp provides DC feedback to bias the output at DC.

An N2 expander is shown in Figure 15. The input level of 3.27V_{RMS} is stepped down to 1.33V by the 600Ω:100Ω transformer, which is terminated with a 100Ω resistor for accurate impedance matching. The output impedance is accurately set by the 150Ω output resistor

Applications for companders NE570/571/SA571

AN174

and the 150Ω:600Ω output transformer. With this configuration, the 3.46V transformer output requires a 3.46V op amp output. To obtain this output level, it is necessary to increase the value of R_3 with an external trim resistor. The new value of R_3 can be found with the expander gain equation

$$R_3 = \frac{R_1 R_2 I_B \text{ Gain}}{2 V_{IN} \text{ avg}}$$

$$= \frac{10k \times 20k \times 140\mu A \times 2.6}{2 \times 1.20}$$

$$= 30.3k$$

An external addition to R_3 of 10k is required, and this value can be selected to accurately set the high level gain.

A low level trim resistor from C_{RECT} to V_{CC} of about 3M provides matching of the Bell low-level tracking curve, and the 2μF value of C_{RECT} provides the proper attack and release times. A 16k resistor from the summing node to ground biases the output to 7V_{DC}.

VOLTAGE-CONTROLLED ATTENUATOR

The variable gain cell in the SA570/571 may be used as the heart of a high quality voltage-controlled amplifier (VCA). Figure 16 shows a typical circuit which uses an external op amp for better performance, and an exponential converter to get a control characteristic of -6dB/V. Trim networks are shown to null out distortion and DC shift, and to fine trim gain to 0dB with 0V of control voltage.

Op amp A_2 and transistors Q_1 and Q_2 form the exponential converter generating an exponential gain control current, which is fed into the rectifier. A reference current of 150μA, (15V and $R_{20}=100k$), is attenuated a factor of two (6dB) for every volt increase in the control voltage. Capacitor C_6 slows down gain changes to a 20ms time constant ($C_6 \times R_1$) so that an abrupt change in the control voltage will produce a smooth sounding gain change. R_{18} assures that for large control voltages the circuit will go to full attenuation. The rectifier bias current would normally limit the gain reduction to about 70dB. R_{18} draws excess current out of the rectifier. After approximately 50dB of attenuation at a -6dB/V slope, the slope steepens and attenuation becomes much more rapid until the circuit totally shuts off at about 9V of control voltage. A_1 should be a low noise high slew rate op amp. R_{13} and R_{14} establish approximately a 0V bias at A_1 's output.

With a 0V control voltage, R_{19} should be adjusted for 0dB gain. At 1V(-6dB gain) R_9 should be adjusted for minimum distortion with a large (+10dBm) input signal. The output DC bias (A_1 output) should be measured at full attenuation (+10V control voltage) and then R_8 is adjusted to give the same value at 0dB gain. Properly adjusted, the circuit will give typically less than 0.1% distortion at any gain with a DC output voltage variation of only a few millivolts. The clipping level (140μA into Pin 3, 14) is ±10V peak. A signal-to-noise ratio of 90dB can be obtained.

If several VCAs must track each other, a common exponential converter can be used. Transistors can simply be added in parallel with Q_2 to control the other channels. The transistors should be maintained at the same temperature for best tracking.

AUTOMATIC LEVEL CONTROL

The SA570 can be used to make a very high performance ALC as shown in Figure 17. This circuit hook-up is very similar to the basic

compressor shown in Figure 2 except that the rectifier input is tied to the input rather than the output. This makes gain inversely proportional to input level so that a 20dB drop in input level will produce a 20dB increase in gain. The output will remain fixed at a constant level. As shown, the circuit will maintain an output level of ±1dB for an input range of +14 to -43dB at 1kHz. Additional external components will allow the output level to be adjusted. Some relevant design equations are:

$$\text{Output level} = \frac{R_1 R_2 I_B}{2 R_3} \left(\frac{V_{IN}}{V_{IN} \text{ (avg)}} \right)$$

$$I_B = 140\text{mA}$$

$$\text{Gain} = \frac{R_1 R_2 I_B}{2 R_3 V_{IN} \text{ (avg)}} \text{ where}$$

$$\frac{V_{IN}}{V_{IN} \text{ (avg)}} = \frac{\pi}{2\sqrt{2}} = 1.11 \text{ (for sine wave)}$$

If ALC action at very low input levels is not desired, the addition of resistor R_X will limit the maximum gain of the circuit.

$$\text{Gain max} = \frac{R_1 + R_X}{1.8V} \times \frac{R_2 \times I_B}{2 R_3}$$

The time constant of the circuit is determined by the rectifier capacitor, C_{RECT} , and an internal 10k resistor.

$$\tau = 10k C_{RECT}$$

Response time can be made faster at the expense of distortion. Distortion can be approximated by the equation:

$$\text{THD} = \left(\frac{1\mu F}{C_{RECT}} \right) \left(\frac{1\text{kHz}}{\text{freq.}} \right) \times 0.2\%$$

VARIABLE SLOPE COMPRESSOR-EXPANDOR

Compression and expansion ratios other than 2:1 can be achieved by the circuit shown in Figure 18. Rotation of the dual potentiometer causes the circuit hook-up to change from a basic compressor to a basic expander. In the center of rotation, the circuit is 1:1, has neither compression nor expansion. The (input) output transfer characteristic is thus continuously variable from 2:1 compression, through 1:1 up to 1:2 expansion. If a fixed compression or expansion ratio is desired, proper selection of fixed resistors can be used instead of the potentiometer. The optional threshold resistor will make the compression or expansion ratio deviate towards 1:1 at low levels. A wide variety of (input) output characteristics can be created with this circuit, some of which are shown in Figure 18.

HI-FI COMPANDOR

The SA570 can be used to construct a high performance compander suitable for use with music. This type of system can be used for noise reduction in tape recorders, transmission systems, bucket brigade delay lines, and digital audio systems. The circuits to be described contain features which improve performance, but are not required for all applications.

A major problem with the simple SA570 compressor (Figure 2) is the limited op amp gain at high frequencies.

Applications for compandors NE570/571/SA571

AN174

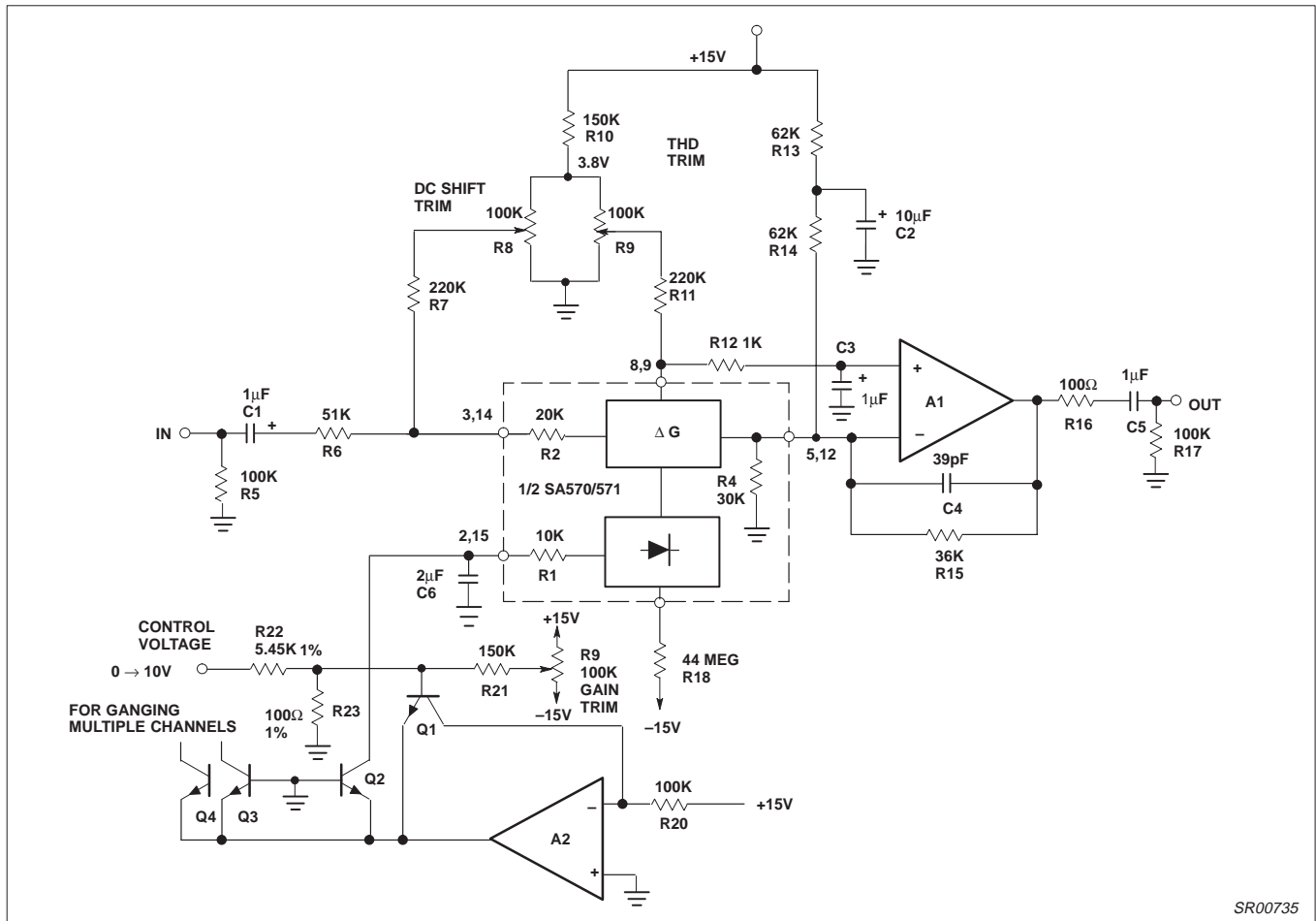

Figure 16. Voltage-Controlled Attenuator

For weak input signals, the compressor circuit operates at high gain and the 570 op amp simply runs out of loop gain. Another problem with the 570 op amp is its limited slew rate of about 0.6V/µs. This is a limitation of the expander, since the expander is more likely to produce large output signals than a compressor.

Figure 20 is a circuit for a high fidelity compressor which uses an external op amp and has a high gain and wide bandwidth. An input compensation network is required for stability.

Another feature of the circuit in Figure 20 is that the rectifier capacitor (C_g) is not grounded, but is tied to the output of an op amp circuit. This circuit, built around an LM324, speeds up the compressor attack time at low signal levels. The response times of the simple expander and compressor (Figures 1 and 2) become

longer at low signal levels. The time constant is not simply 10k×C_{RECT}, but is really:

$$\left(10k + 2 \left(\frac{0.026V}{I_{RECT}} \right) \right) \times C_{RECT}$$

When the rectifier input level drops from 0dBm to -30dBm, the time constant increases from 10.7k×C_{RECT} to 32.6k×C_{RECT}. In systems where there is unity gain between the compressor and expander, this will cause no overall error. Gain or loss between the compressor and expander will be a mistracking of low signal dynamics. The circuit with the LM324 will greatly reduce this problem for systems which cannot guarantee the unity gain.

Applications for comparators NE570/571/SA571

AN174

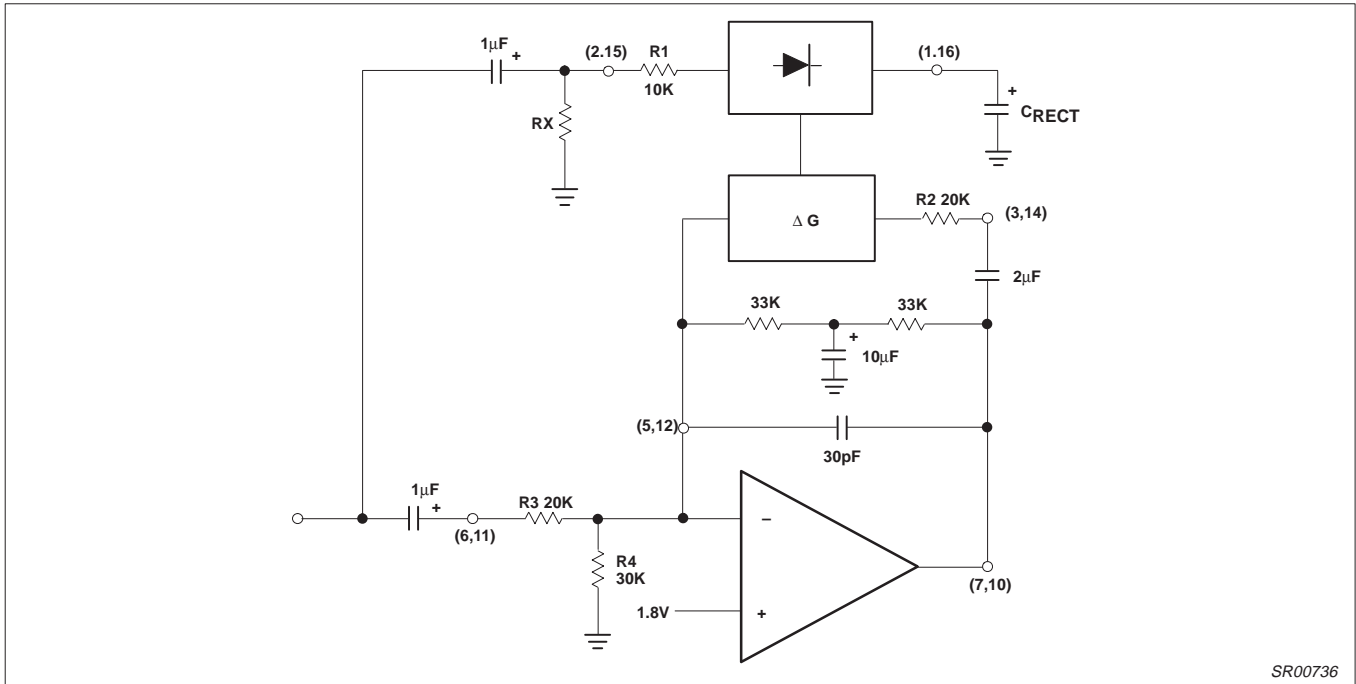

Figure 17. Automatic Level Control

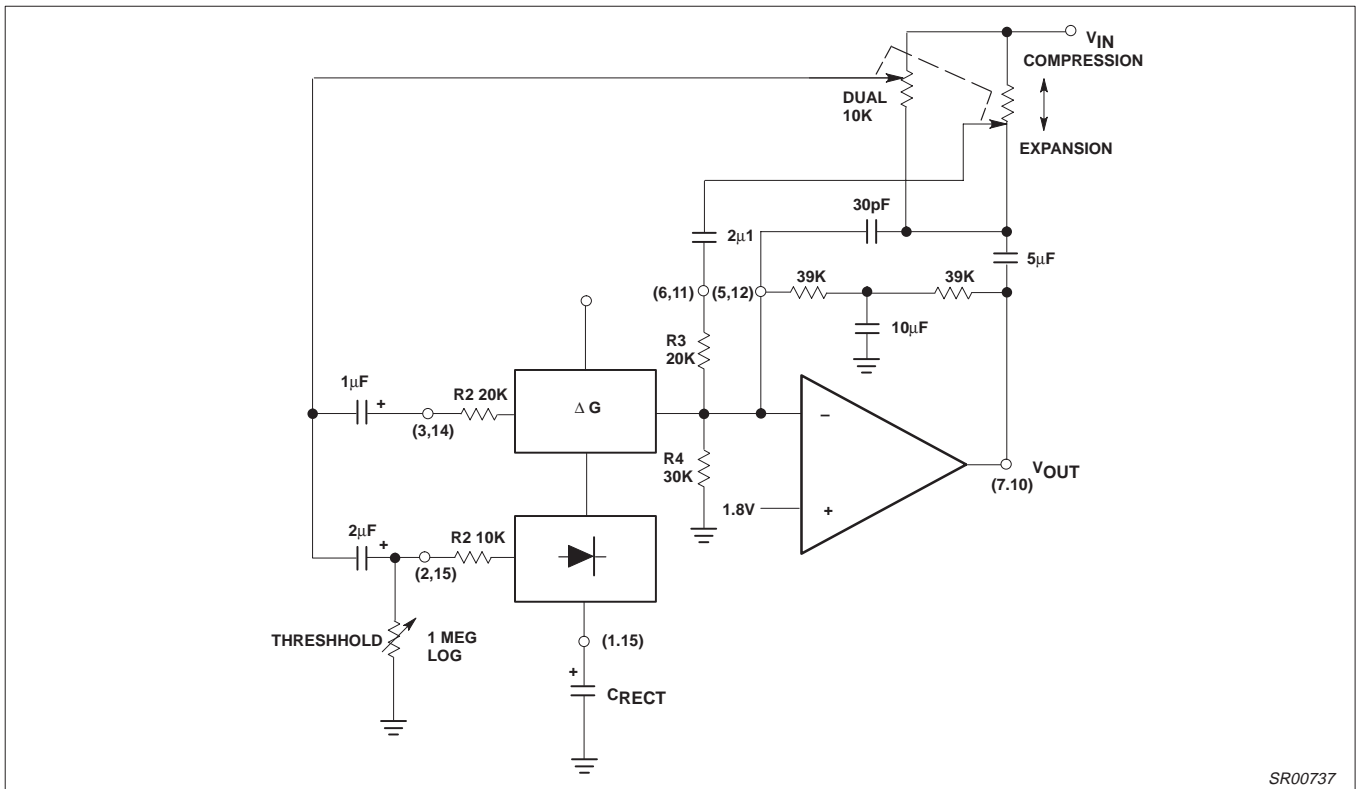

Figure 18. Variable Slope Compressor-Expander

Applications for companders NE570/571/SA571

AN174

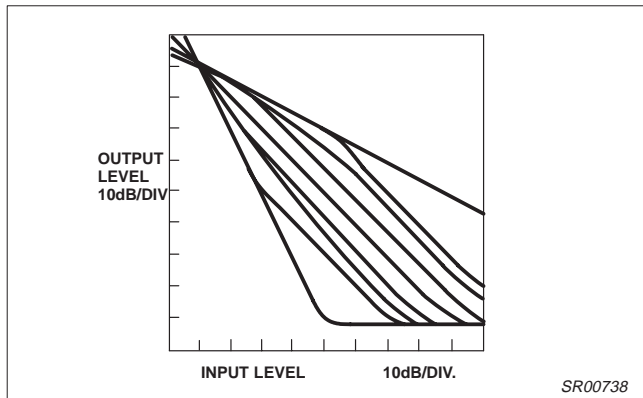

Figure 19. Typical Input-Output Tracking Curves of Variable Ratio Compressor-Expander

When a compressor is operating at high gain, (small input signal), and is suddenly hit with a signal, it will overload until it can reduce its gain. Overloaded, the output will attempt to swing rail to rail. This compressor is limited to approximately a 7V_{P-P} output swing by the brute force clamp diodes D₃ and D₄. The diodes cannot be placed in the feedback loop because their capacitance would limit high frequency gain. The purpose of limiting the output swing is to avoid overloading any succeeding circuit such as a tape recorder input.

The time it takes for the compressor to recover from overload is determined by the rectifier capacitor C₉. A smaller capacitor will

allow faster response to transients, but will produce more low frequency third harmonic distortion due to gain modulation. A value of 1μF seems to be a good compromise value and yields good subjective results. Of course, the expander should have exactly the same value rectifier capacitor for proper transient response. Systems which have good low frequency amplitude and phase response can use companders with smaller rectifier capacitors, since the third harmonic distortion which is generated by the compressor will be undistorted by the expander.

Simple compander systems are subject to a problem known as breathing. As the system is changing gain, the change in the background noise level can sometimes be heard.

The compressor in Figure 20 contains a high frequency pre-emphasis circuit (C₂, R₅ and C₈, R₁₄), which helps solve this problem. Matching de-emphasis on the expander is required. More complex designs could make the pre-emphasis variable and further reduce breathing.

The expander to complement the compressor is shown in Figure 21. Here an external op amp is used for high slew rate. Both the compressor and expander have unity gain levels of 0dB. Trim networks are shown for distortion (THD) and DC shift. The distortion trim should be done first, with an input of 0dB at 10kHz. The DC shift should be adjusted for minimum envelope bounce with tone bursts. When applied to consumer tape recorders, the subjective performance of this system is excellent.

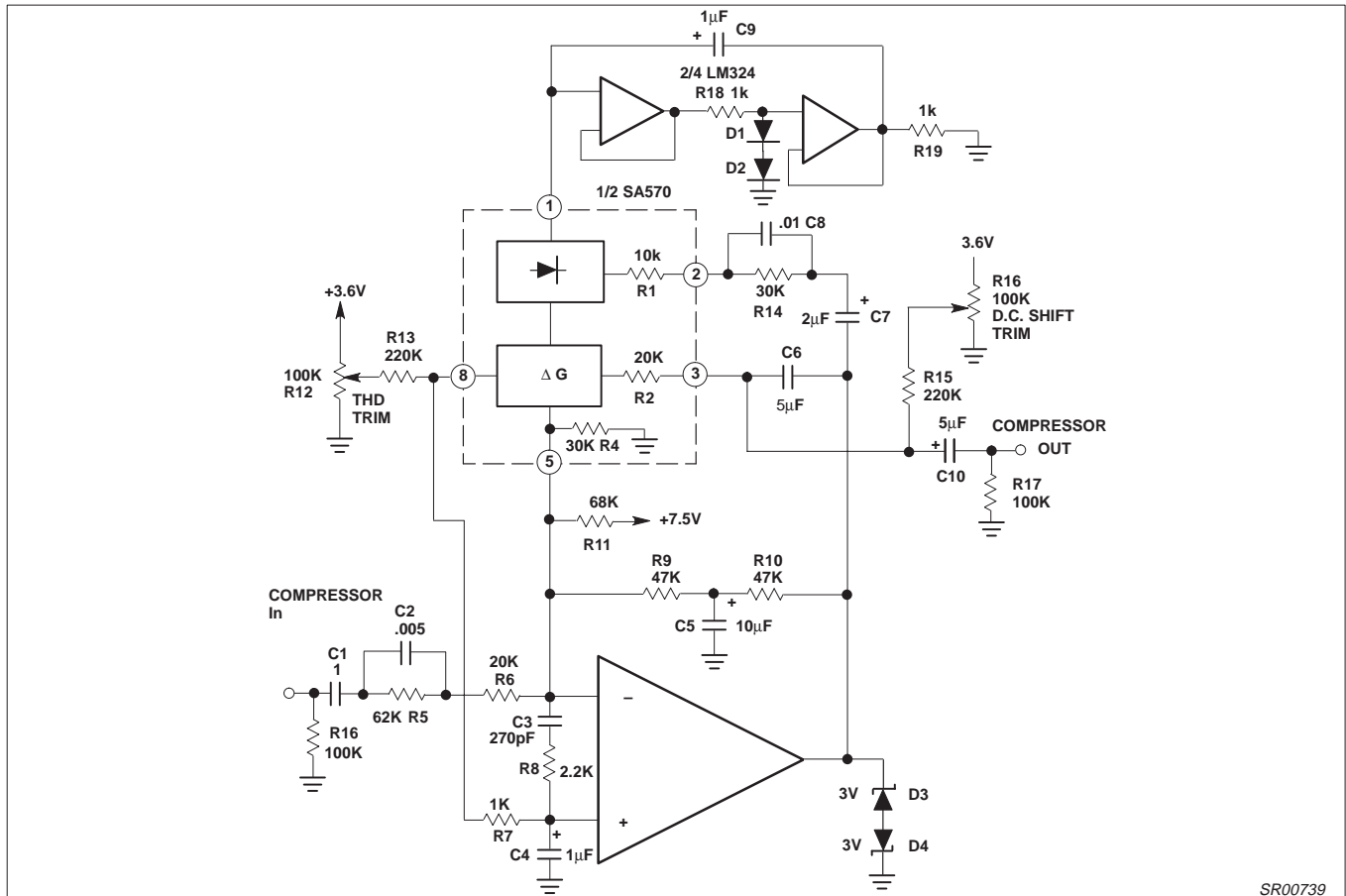

Figure 20. Hi-Fi Compressor With Pre-emphasis

Applications for companders NE570/571/SA571

AN174

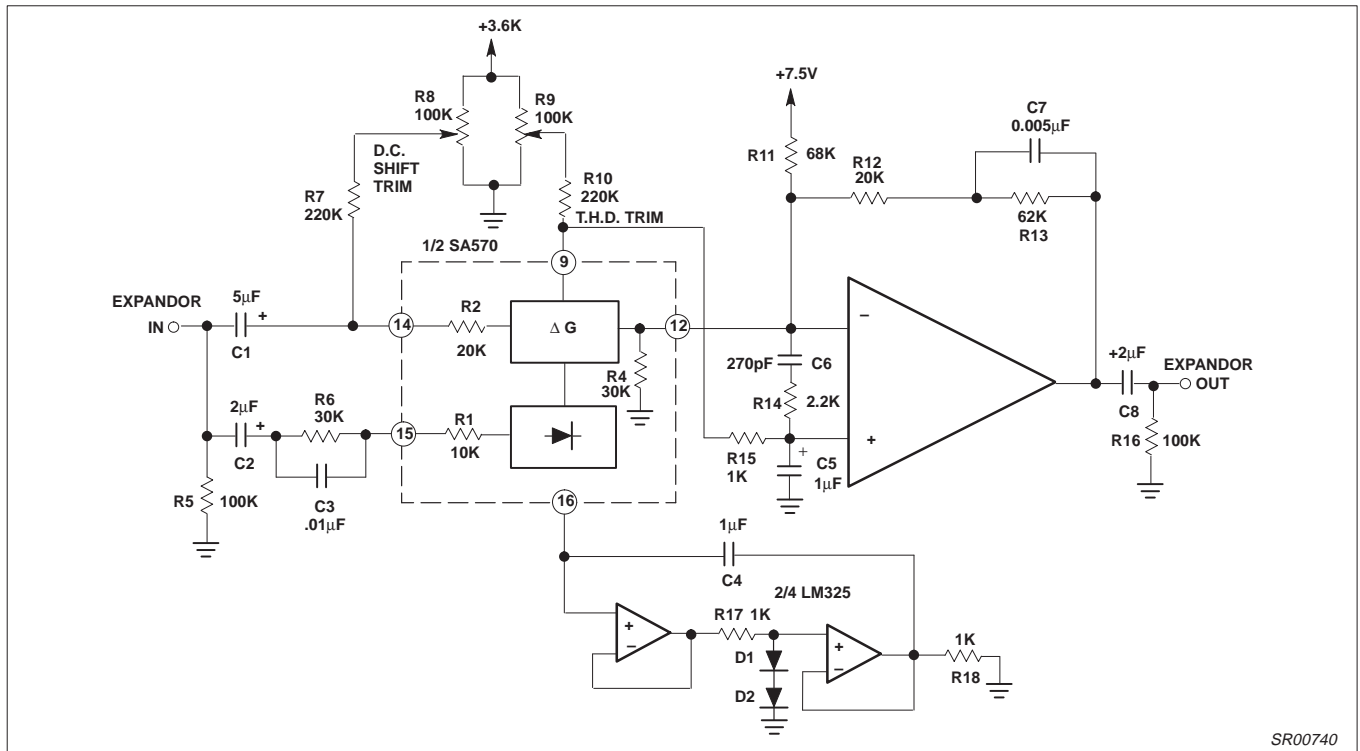

Figure 21. Hi-Fi Expander With De-emphasis

SR00740