



**TS861
TS862
TS864**

RAIL TO RAIL MICROPOWER BICMOS COMPARATORS

- ULTRA LOW CURRENT CONSUMPTION (**6 μ A/comp at V_{CC}=2.7V**)
- **RAIL TO RAIL CMOS INPUTS**
- **PUSH PULL OUTPUTS**
- SUPPLY OPERATION FROM **2.7V TO 10V**
- LOW PROPAGATION DELAY
- LOW FALL AND RISE TIME: 20ns
- ESD PROTECTION (**2kV**)
- LATCH-UP IMMUNITY (**Class A**)
- AVAILABLE IN **SOT23-5 MICROPACKAGE**

DESCRIPTION

The TS86x (Single, Dual & Quad) is a Rail to Rail comparator characterized for 2.7V to 10V operation over -40°C to +85°C temperature range. It exhibits an excellent speed to power ratio, featuring a current consumption of 6 μ A per comparator and a response time of 500ns at 2.7V for 100mV overdrive.

Due to its ultra low power consumption and its availability in tiny package, the TS86x comparator family is perfectly suited to battery powered systems. The output stage is designed with a push pull structure allowing a direct connection to microcontroller without additional pull-up resistor.

APPLICATION

- Battery-powered systems (eg: Alarm)
- Portable communication systems
- Smoke/gas/fire detectors
- Portable computers

ORDER CODE

| Part Number | Temperature Range | Package | | | | SOT23 Marking |
|-------------------|-------------------|---------|---|---|---|---------------|
| | | N | D | P | L | |
| TS861I TS861AI | -40, +85°C | • | • | | • | K501 K502 |
| TS862I TS862AI | -40, +85°C | • | • | • | | |
| TS864I TS864AI | -40, +85°C | • | • | • | | |

N = Dual in Line Package (DIP)
D = Small Outline Package (SO) - also available in Tape & Reel (DT)
P = Thin Shrink Small Outline Package (TSSOP) - only available in Tape & Reel (PT)
L = Tiny Package (SOT23-5) - only available in Tape & Reel (LT)

PIN CONNECTIONS (top view)

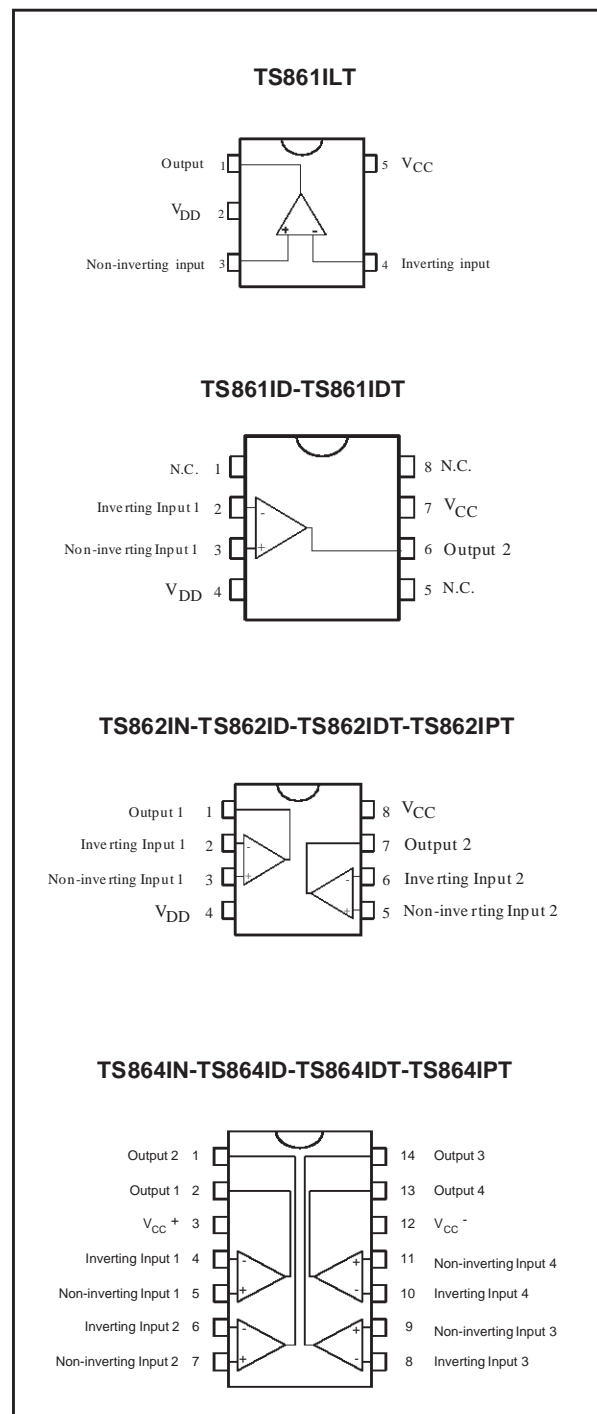

TS861-TS862-TS864

ABSOLUTE MAXIMUM RATINGS

| Symbol | Parameter | Value | Unit |
|------------|--|--|------|
| V_{CC} | Supply voltage ¹⁾ | 12 | V |
| V_{id} | Differential Input Voltage ²⁾ | ± 12 | V |
| V_{in} | Input Voltage Range ³⁾ | -0.3 to 12.3 | V |
| T_{oper} | Operating Free Air Temperature Range | -40 to + 85 | °C |
| T_{std} | Storage Temperature Range | -65 to +150 | °C |
| T_j | Maximum Junction Temperature | 150 | °C |
| R_{thja} | Thermal Resistance Junction to Ambient ⁴⁾ SOT23-5 DIP8 DIP14 SO8 SO14 TSSOP8 TSSOP14 | 250 100 80 175 150 200 175 | °C/W |
| ESD | Human Body Model | 2 | kV |
| | Machine Model | 200 | V |
| | Latch-up Immunity | Class A | |
| | Lead Temperature (soldering, 10sec) | 260 | °C |

1. All voltages values, except differential voltage are with respect to network terminal.
2. Differential voltages are non-inverting input terminal with respect to the inverting input terminal.
3. The magnitude of input and output voltages must never exceed $V_{CC} + 0.3V$.
4. Short-circuits can cause excessive heating and destructive dissipation.

OPERATING CONDITIONS

| Symbol | Parameter | Value | Unit |
|-----------|---------------------------------|--------------------------------------|------|
| V_{CC} | Supply Voltage | 2.7 to 10 | V |
| V_{icm} | Common Mode Input Voltage Range | $V_{CC}^- - 0.3$ to $V_{CC}^+ + 0.3$ | V |

ELECTRICAL CHARACTERISTICS

V_{CC} = +2.7V

T_{amb} = 25°C (unless otherwise specified)

| Symbol | Parameter | Min. | Typ. | Max. | Unit |
|------------------|---|--------------|------------|--------------|-------|
| V _{io} | Input Offset Voltage TS861/2/4 Tmin<T<Tmax | | 3 | 15 18 | mV |
| | TS861/2/4A Tmin<T<Tmax | | 3 | 7 10 | |
| ΔV _{io} | Input Offset Voltage Drift | | 6 | | μV/°C |
| I _{io} | Input Offset Current ¹⁾ Tmin<T<Tmax | | 1 | 150 300 | pA |
| I _{ib} | Input Bias Current ¹⁾ Tmin<T<Tmax | | 1 | 300 600 | pA |
| V _{OH} | High Level Output Voltage I _{source} =2.5mA Tmin<T<Tmax | 2.35 2.15 | 2.45 | | V |
| V _{OL} | Low Level Output Voltage I _{sink} =2.5mA Tmin<T<Tmax | | 0.2 | 0.35 0.45 | V |
| A _{vd} | Large Signal Voltage Gain ²⁾ | | 240 | | dB |
| CMR | Common Mode Rejection Ratio 0 < V _{ICM} < 2.7V | | 65 | | dB |
| SVR | Supply Voltage Rejection Ratio 0 < V _{CC} < 10V | | 80 | | dB |
| I _{CC} | Supply current per comparator no load, output low no load, output high | | 6 8 | 12 14 | μA |
| | | | | | |
| T _{plh} | Propagation delay from output low to output high V _{ICM} =1.35V, f=10kHz, C _L =50pF overdrive = 10mV overdrive = 100mV | | 1.5 0.6 | | μs |
| T _{phl} | Propagation delay from output high to output low V _{ICM} =1.35V, f=10kHz, C _L =50pF overdrive = 10mV overdrive = 100mV | | 1.5 0.5 | | μs |
| T _f | Fall time f=10kHz, C _L =50pF, overdrive=100mV | | 20 | | ns |
| T _r | Rise time f=10kHz, C _L =50pF, overdrive=100mV | | 20 | | ns |

1. Maximum values including unavoidable inaccuracies of the industrial test.

2. Design evaluation

3. Limits are 100% production tested at 25°C. Limits over temperature are guaranteed through correlation and by design.

TS861-TS862-TS864

ELECTRICAL CHARACTERISTICS

$V_{CC} = +5V$

$T_{amb} = 25^{\circ}C$ (unless otherwise specified)

| Symbol | Parameter | Min. | Typ. | Max. | Unit |
|-----------------|--|-------------|----------|-------------|-------------------|
| V_{io} | Input Offset Voltage TS861/2/4 $T_{min} < T < T_{max}$ | | 3 | 15 18 | mV |
| | TS861/2/4A $T_{min} < T < T_{max}$ | | 3 | 7 10 | |
| ΔV_{io} | Input Offset Voltage Drift | | 6 | | $\mu V/^{\circ}C$ |
| I_{io} | Input Offset Current ¹⁾ $T_{min} < T < T_{max}$ | | 1 | 150 300 | pA |
| I_{ib} | Input Bias Current ¹⁾ $T_{min} < T < T_{max}$ | | 1 | 300 600 | pA |
| V_{OH} | High Level Output Voltage $I_{source} = 5mA$ $T_{min} < T < T_{max}$ | 4.6 4.45 | 4.8 | | V |
| V_{OL} | Low Level Output Voltage $I_{sink} = 5mA$ $T_{min} < T < T_{max}$ | | 0.2 | 0.4 0.55 | V |
| A_{vd} | Large Signal Voltage Gain ²⁾ | | 240 | | dB |
| CMR | Common Mode Rejection Ratio $0 < V_{ICM} < 5V$ | | 70 | | dB |
| SVR | Supply Voltage Rejection Ratio $2.7 < V_{CC} < 10V$ | | 80 | | dB |
| I_{CC} | Supply current per comparator no load, output low no load, output high | | 6 8 | 12 14 | μA |
| T_{plh} | Propagation delay from output low to output high $V_{ICM} = 2.5V$, $f = 10kHz$, $C_L = 50pF$ overdrive = 10mV overdrive = 100mV | | 2 0.5 | | μs |
| T_{phl} | Propagation delay from output high to output low $V_{ICM} = 2.5V$, $f = 10kHz$, $C_L = 50pF$ overdrive = 10mV overdrive = 100mV | | 2 0.4 | | μs |
| T_f | Fall time $f = 10kHz$, $C_L = 50pF$, overdrive = 100mV | | 20 | | ns |
| T_r | Rise time $f = 10kHz$, $C_L = 50pF$, overdrive = 100mV | | 20 | | ns |

1. Maximum values including unavoidable inaccuracies of the industrial test..

2. Design evaluation

3. Limits are 100% production tested at 25°C. Limits over temperature are guaranteed through correlation and by design

ELECTRICAL CHARACTERISTICS

V_{CC} = +10V

T_{amb} = 25°C (unless otherwise specified)

| Symbol | Parameter | Min. | Typ. | Max. | Unit |
|------------------|--|-------------|------------|-------------|-------|
| V _{io} | Input Offset Voltage (V _{ICM} = V _{CC} / 2) TS861/2/4 Tmin<T<Tmax | | 3 | 15 18 | mV |
| ΔV _{io} | Input Offset Voltage Drift | | 6 | | μV/°C |
| I _{io} | Input Offset Current ¹⁾ Tmin<T<Tmax | | 1 | 150 300 | pA |
| I _{ib} | Input Bias Current ¹⁾ Tmin<T<Tmax | | 1 | 300 600 | pA |
| V _{OH} | High Level Output Voltage I _{source} =5mA Tmin<T<Tmax | 9.6 9.45 | 9.8 | | V |
| V _{OL} | Low Level Output Voltage I _{sink} =5mA Tmin<T<Tmax | | 0.2 | 0.4 0.55 | V |
| A _{vd} | Large Signal Voltage Gain ²⁾ | | 240 | | dB |
| CMR | Common Mode Rejection Ratio 0 < V _{ICM} < 10V | | 75 | | dB |
| SVR | Supply Voltage Rejection Ratio 2.7 < V _{CC} < 10V | | 80 | | dB |
| I _{CC} | Supply current per comparator no load, output low no load, output high | | 7 10 | 14 16 | μA |
| T _{plh} | Propagation delay from output low to output high V _{ICM} =5V, f=10kHz, C _L =50pF overdrive = 10mV overdrive = 100mV | | 3 0.5 | | μs |
| T _{phl} | Propagation delay from output high to output low V _{ICM} =5V, f=10kHz, C _L =50pF overdrive = 10mV overdrive = 100mV | | 2.6 0.4 | | μs |
| T _f | Fall time f=10kHz, C _L =50pF, overdrive=100mV | | 20 | | ns |
| T _r | Rise time f=10kHz, C _L =50pF, overdrive=100mV | | 20 | | ns |

1. Maximum values including unavoidable inaccuracies of the industrial test.

2. Design evaluation

3. Limits are 100% production tested at 25°C. Limits over temperature are guaranteed through correlation and by design.

TS861-TS862-TS864

V_{IO} versus V_{ICM} at $V_{CC} = 2.7V$

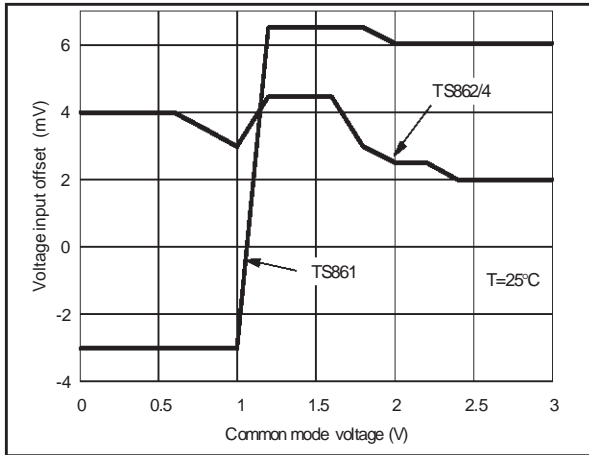

V_{IO} versus V_{ICM} and temperature at $V_{CC} = 2.7V$

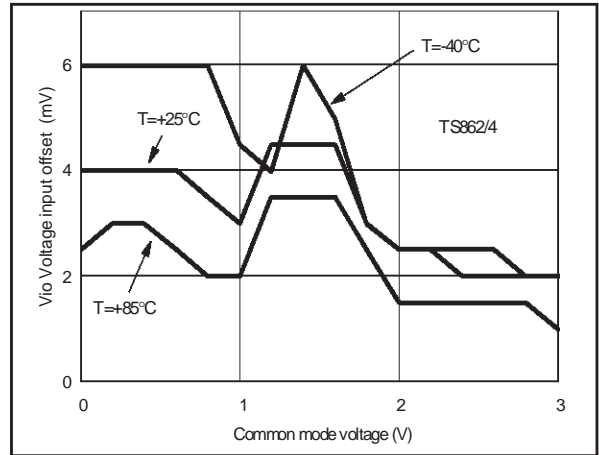

V_{IO} versus V_{ICM} at $V_{CC} = 5V$

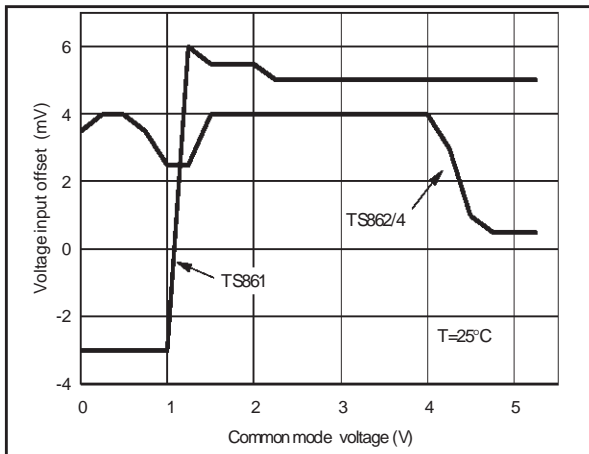

V_{IO} versus V_{ICM} and temperature at $V_{CC} = 5V$

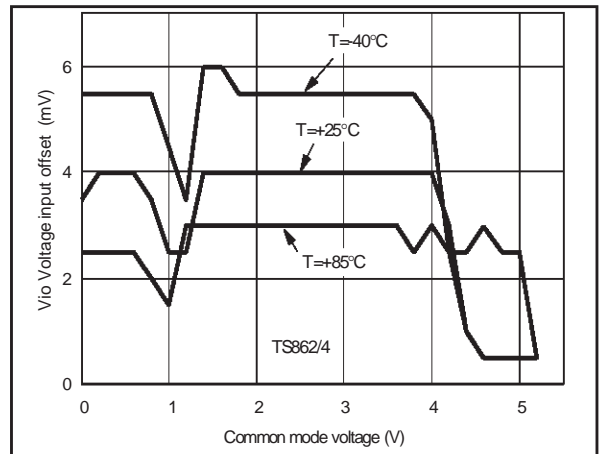

V_{IO} versus V_{ICM} at $V_{CC} = 10V$

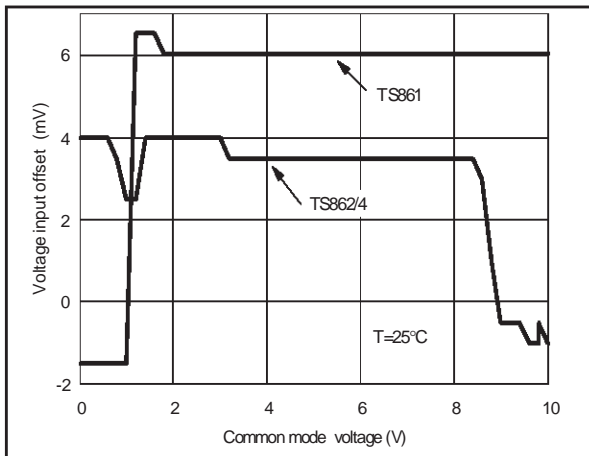

V_{IO} versus V_{ICM} and temperature at $V_{CC} = 10V$

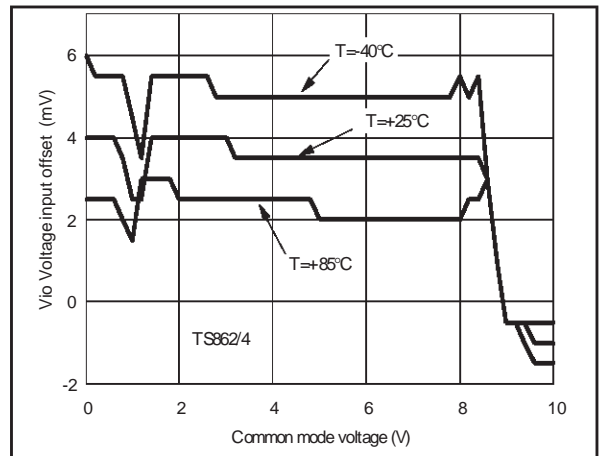

V_{IO} versus V_{CC} at $V_{ICM} = V_{CC} / 2$

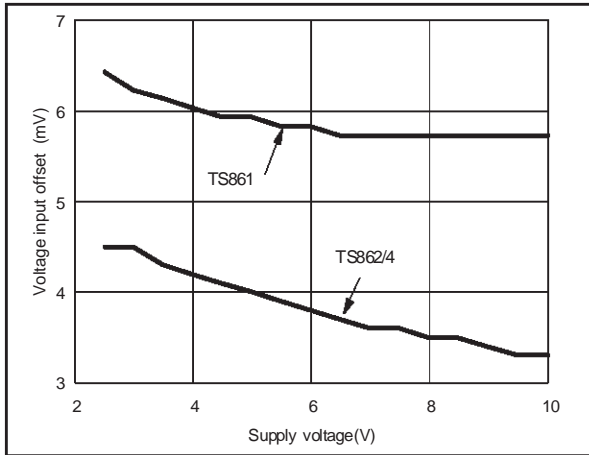

V_{IO} versus temperature at $V_{CC} = 5V$

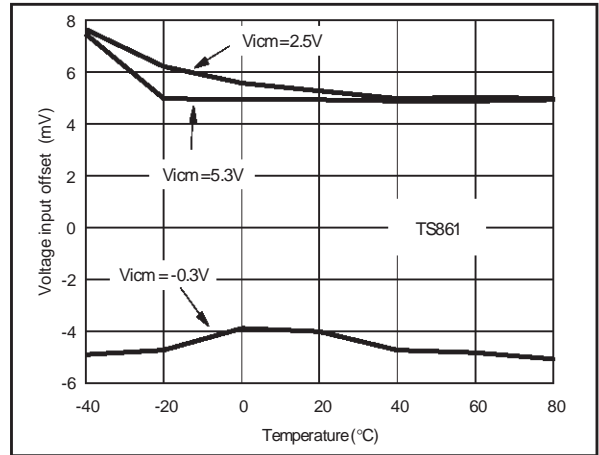

Supply Current (I_{CC}) vs Supply Voltage (V_{CC})

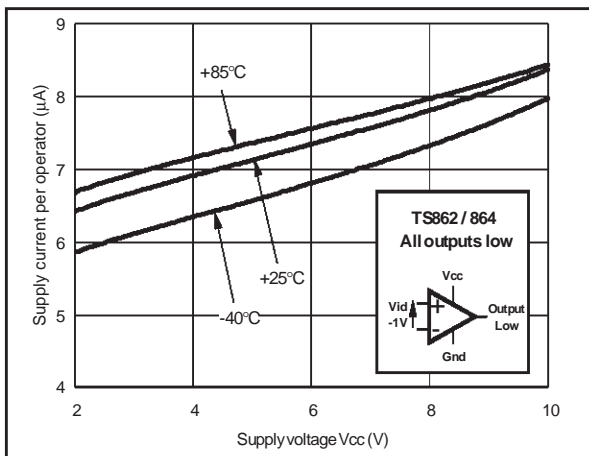

Supply Current (I_{CC}) vs Supply Voltage (V_{CC})

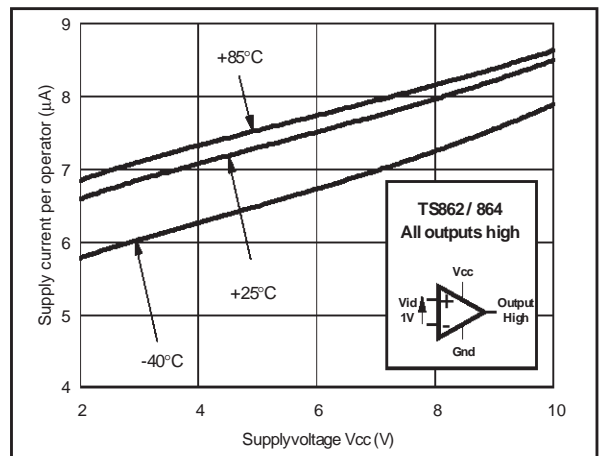

Supply Current (I_{CC}) vs Temperature

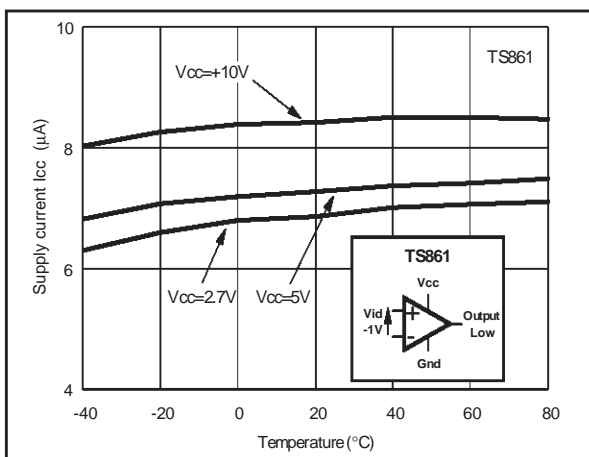

Supply Current (I_{CC}) vs Temperature

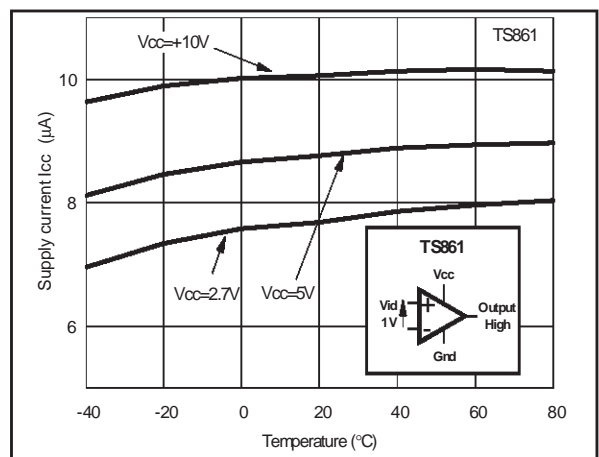

TS861-TS862-TS864

V_{OL} versus I_{SINK} and temperature at $V_{CC}=5V$

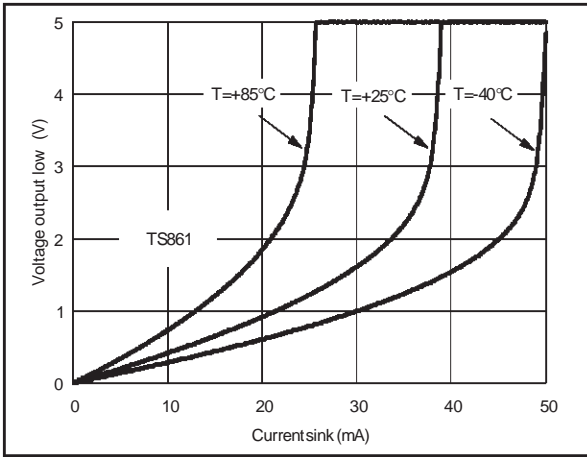

V_{OH} vs I_{SOURCE} and temperature at $V_{CC}=5V$

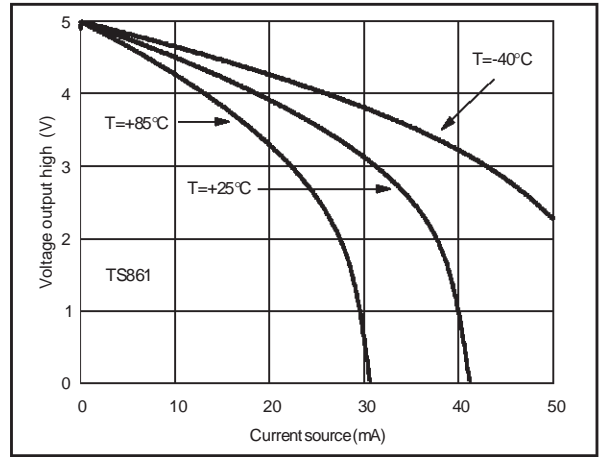

Response time T_{PHL} at $V_{CC}= 2.7V$

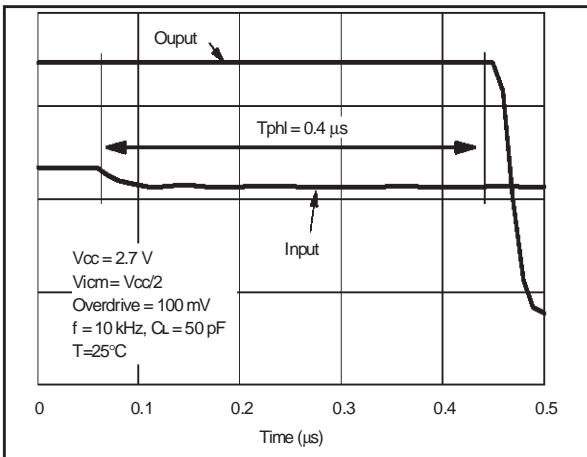

Response time T_{PLH} at $V_{CC}= 2.7V$

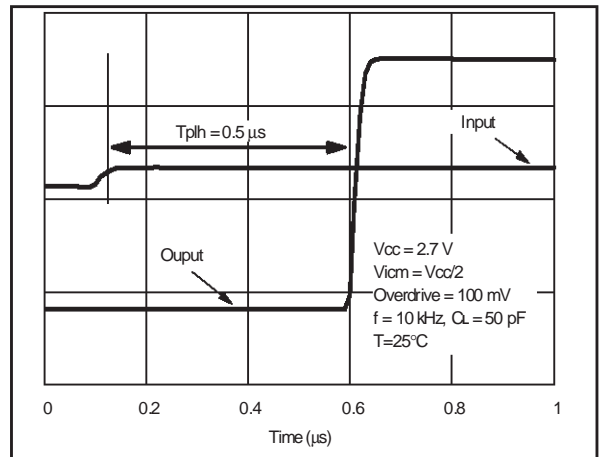

Response time T_{PHL} at $V_{CC}= 5V$

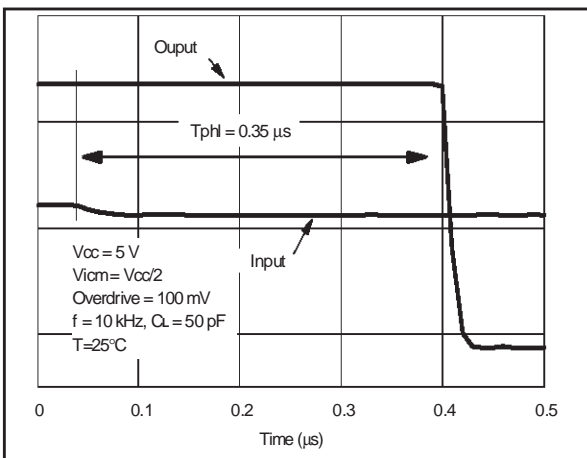

Response time T_{PLH} at $V_{CC}= 5V$

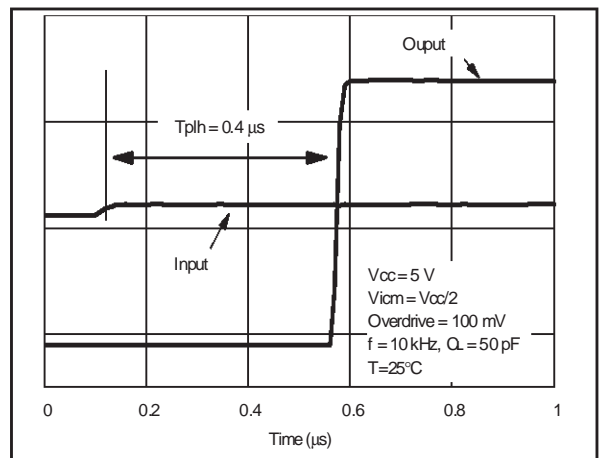

TS861IN - TS862IN

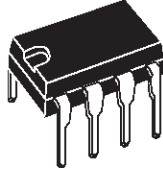

PACKAGE MECHANICAL DATA
8 PINS - PLASTIC PACKAGE

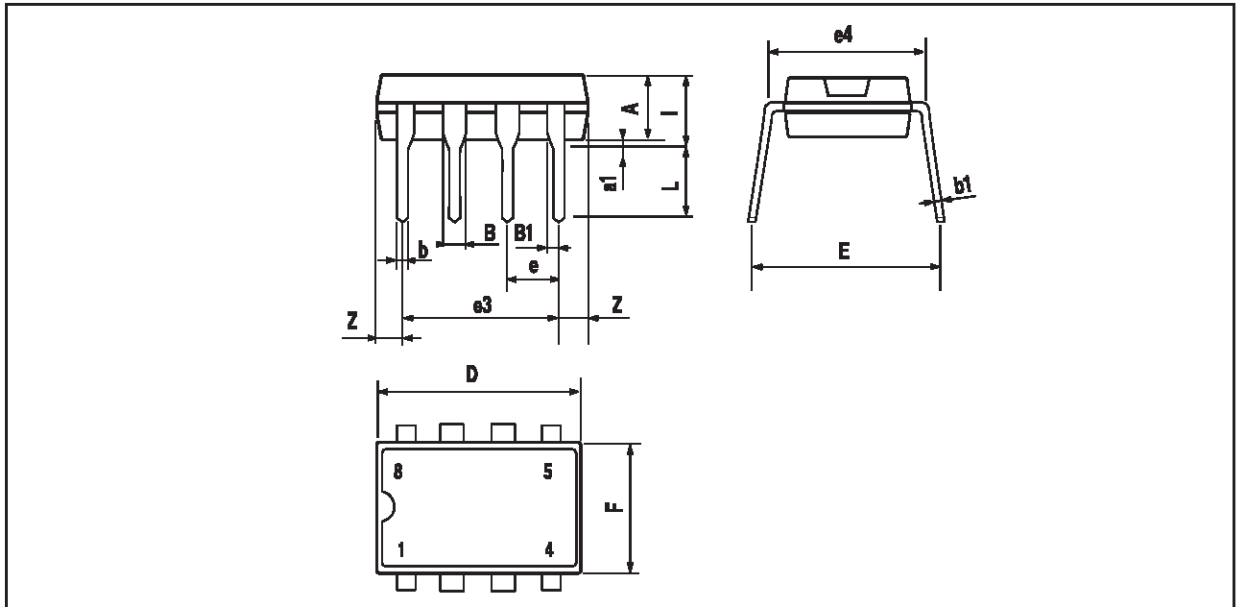

| Dim. | Millimeters | | | Inches | | |
|------|-------------|------|-------|--------|-------|-------|
| | Min. | Typ. | Max. | Min. | Typ. | Max. |
| A | | 3.32 | | | 0.131 | |
| a1 | 0.51 | | | 0.020 | | |
| B | 1.15 | | 1.65 | 0.045 | | 0.065 |
| b | 0.356 | | 0.55 | 0.014 | | 0.022 |
| b1 | 0.204 | | 0.304 | 0.008 | | 0.012 |
| D | | | 10.92 | | | 0.430 |
| E | 7.95 | | 9.75 | 0.313 | | 0.384 |
| e | | 2.54 | | | 0.100 | |
| e3 | | 7.62 | | | 0.300 | |
| e4 | | 7.62 | | | 0.300 | |
| F | | | 6.6 | | | 0.260 |
| i | | | 5.08 | | | 0.200 |
| L | 3.18 | | 3.81 | 0.125 | | 0.150 |
| Z | | | 1.52 | | | 0.060 |

TS861-TS862-TS864

TS861ID - TS862ID

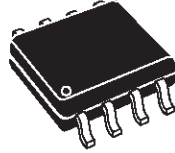

PACKAGE MECHANICAL DATA
8 PINS - PLASTIC MICROPACKAGE (SO)

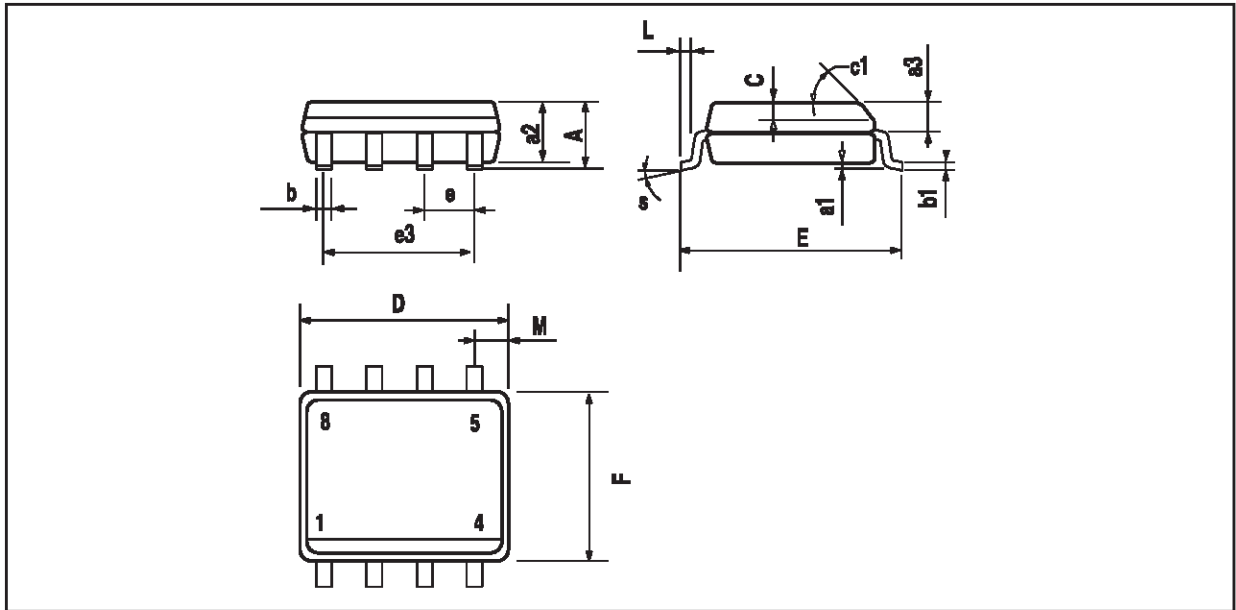

| Dim. | Millimeters | | | Inches | | |
|------|-------------|------|------|--------|-------|-------|
| | Min. | Typ. | Max. | Min. | Typ. | Max. |
| A | | | 1.75 | | | 0.069 |
| a1 | 0.1 | | 0.25 | 0.004 | | 0.010 |
| a2 | | | 1.65 | | | 0.065 |
| a3 | 0.65 | | 0.85 | 0.026 | | 0.033 |
| b | 0.35 | | 0.48 | 0.014 | | 0.019 |
| b1 | 0.19 | | 0.25 | 0.007 | | 0.010 |
| C | 0.25 | | 0.5 | 0.010 | | 0.020 |
| c1 | 45° (typ.) | | | | | |
| D | 4.8 | | 5.0 | 0.189 | | 0.197 |
| E | 5.8 | | 6.2 | 0.228 | | 0.244 |
| e | | 1.27 | | | 0.050 | |
| e3 | | 3.81 | | | 0.150 | |
| F | 3.8 | | 4.0 | 0.150 | | 0.157 |
| L | 0.4 | | 1.27 | 0.016 | | 0.050 |
| M | | | 0.6 | | | 0.024 |
| S | 8° (max.) | | | | | |

TS862IPT

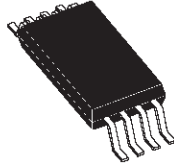

PACKAGE MECHANICAL DATA
8 PINS - THIN SHRINK SMALL OUTLINE PACKAGE

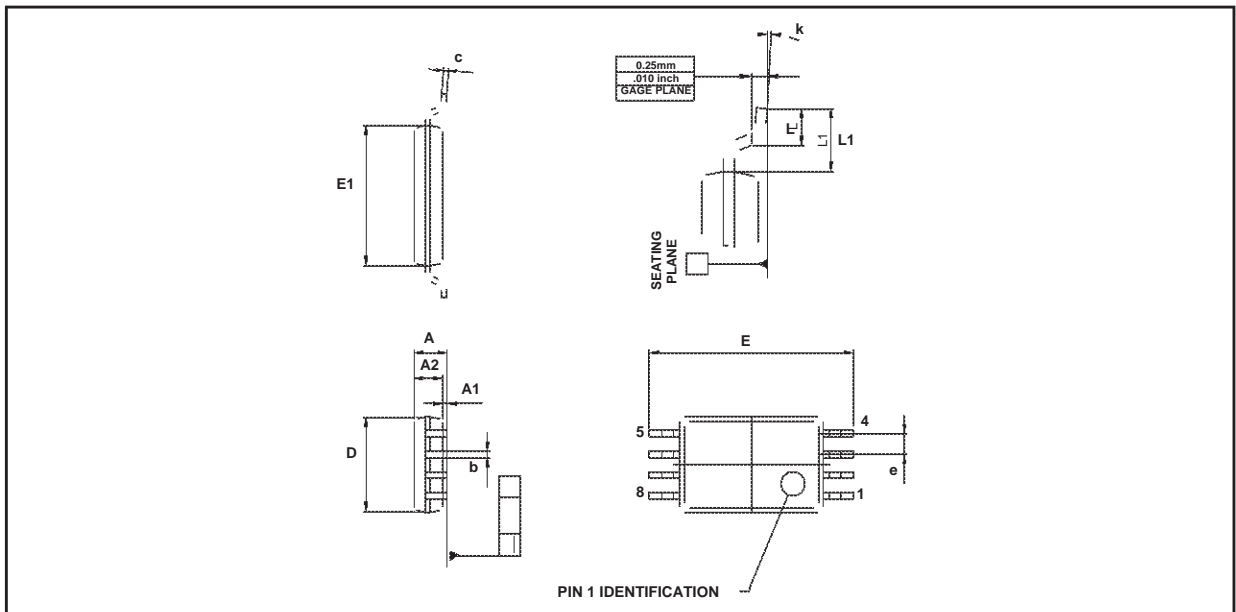

| Dim. | Millimeters | | | Inches | | |
|------|-------------|------|------|--------|--------|-------|
| | Min. | Typ. | Max. | Min. | Typ. | Max. |
| A | | | 1.20 | | | 0.05 |
| A1 | 0.05 | | 0.15 | 0.01 | | 0.006 |
| A2 | 0.80 | 1.00 | 1.05 | 0.031 | 0.039 | 0.041 |
| b | 0.19 | | 0.30 | 0.007 | | 0.15 |
| c | 0.09 | | 0.20 | 0.003 | | 0.012 |
| D | 2.90 | 3.00 | 3.10 | 0.114 | 0.118 | 0.122 |
| E | | 6.40 | | | 0.252 | |
| E1 | 4.30 | 4.40 | 4.50 | 0.169 | 0.173 | 0.177 |
| e | | 0.65 | | | 0.025 | |
| k | 0° | | 8° | 0° | | 8° |
| l | 0.50 | 0.60 | 0.75 | 0.09 | 0.0236 | 0.030 |

TS861-TS862-TS864

TS864IN

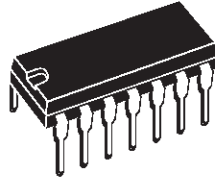

PACKAGE MECHANICAL DATA
14 PINS - PLASTIC PACKAGE

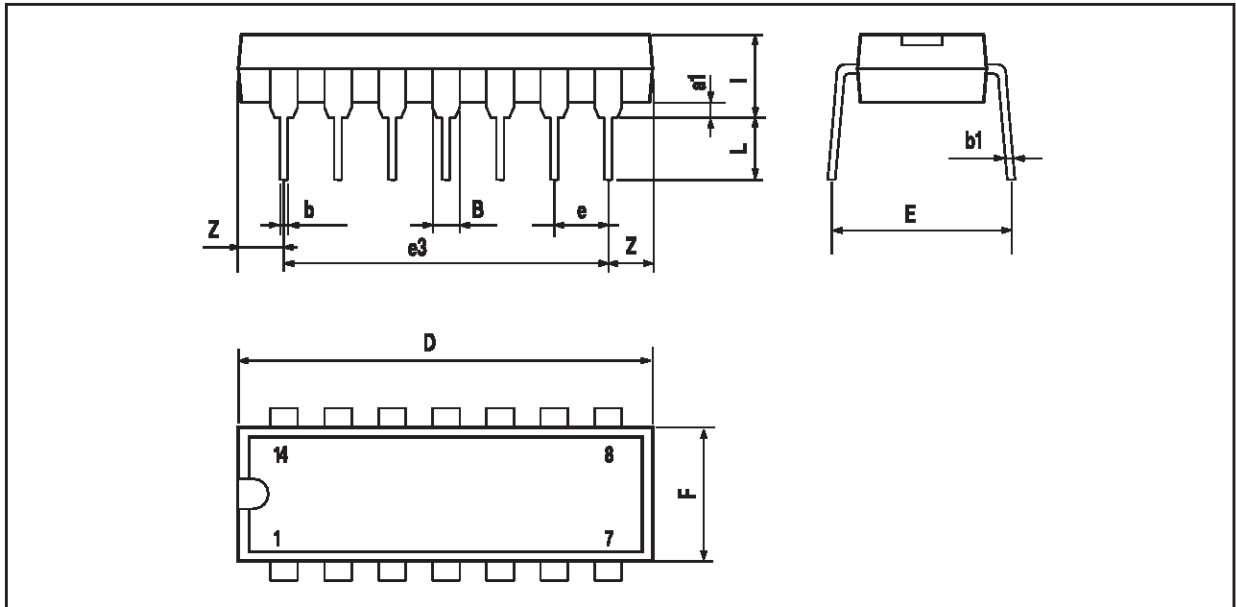

| Dim. | Millimeters | | | Inches | | |
|------|-------------|-------|------|--------|-------|-------|
| | Min. | Typ. | Max. | Min. | Typ. | Max. |
| a1 | 0.51 | | | 0.020 | | |
| B | 1.39 | | 1.65 | 0.055 | | 0.065 |
| b | | 0.5 | | | 0.020 | |
| b1 | | 0.25 | | | 0.010 | |
| D | | | 20 | | | 0.787 |
| E | | 8.5 | | | 0.335 | |
| e | | 2.54 | | | 0.100 | |
| e3 | | 15.24 | | | 0.600 | |
| F | | | 7.1 | | | 0.280 |
| i | | | 5.1 | | | 0.201 |
| L | | 3.3 | | | 0.130 | |
| Z | 1.27 | | 2.54 | 0.050 | | 0.100 |

TS864ID

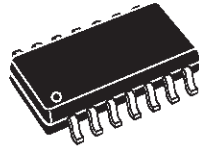

PACKAGE MECHANICAL DATA
14 PINS - PLASTIC MICROPACKAGE (SO)

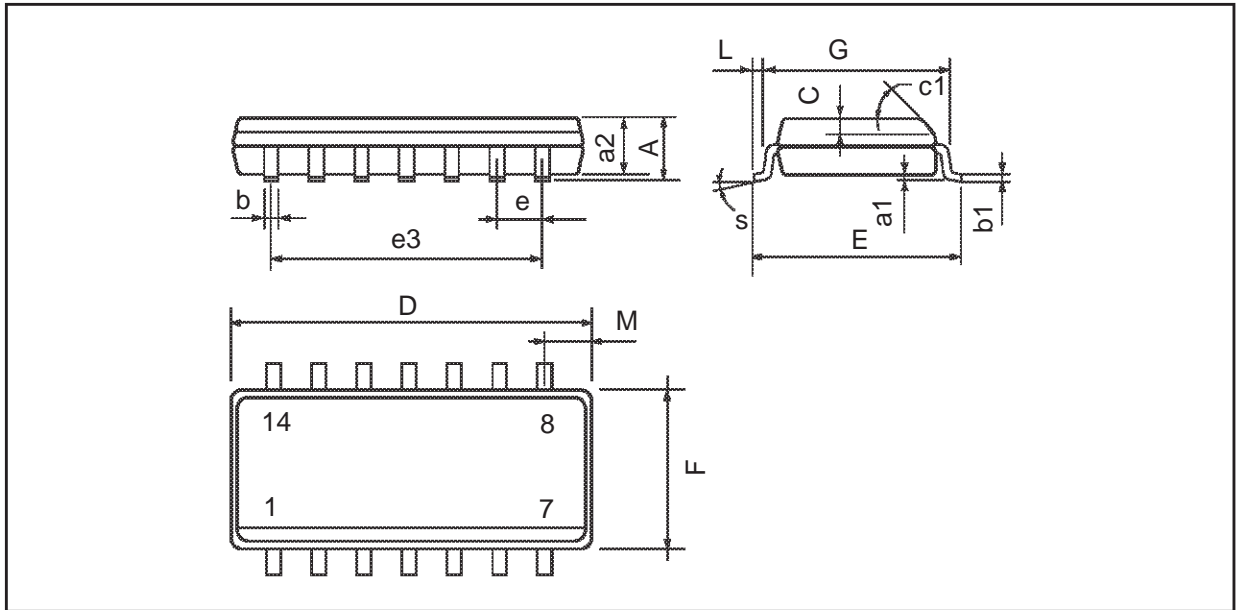

| Dim. | Millimeters | | | Inches | | |
|-------|-------------|------|------|--------|-------|-------|
| | Min. | Typ. | Max. | Min. | Typ. | Max. |
| A | | | 1.75 | | | 0.069 |
| a1 | 0.1 | | 0.2 | 0.004 | | 0.008 |
| a2 | | | 1.6 | | | 0.063 |
| b | 0.35 | | 0.46 | 0.014 | | 0.018 |
| b1 | 0.19 | | 0.25 | 0.007 | | 0.010 |
| C | | 0.5 | | | 0.020 | |
| c1 | 45° (typ.) | | | | | |
| D (1) | 8.55 | | 8.75 | 0.336 | | 0.344 |
| E | 5.8 | | 6.2 | 0.228 | | 0.244 |
| e | | 1.27 | | | 0.050 | |
| e3 | | 7.62 | | | 0.300 | |
| F (1) | 3.8 | | 4.0 | 0.150 | | 0.157 |
| G | 4.6 | | 5.3 | 0.181 | | 0.208 |
| L | 0.5 | | 1.27 | 0.020 | | 0.050 |
| M | | | 0.68 | | | 0.027 |
| S | 8° (max.) | | | | | |

Note : (1) D and F do not include mold flash or protrusions - Mold flash or protrusions shall not exceed 0.15mm (.066 inc) ONLY FOR DATA BOOK.

TS861-TS862-TS864

TS864IPT

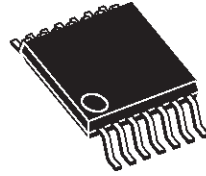

PACKAGE MECHANICAL DATA
14 PINS - THIN SHRINK SMALL OUTLINE PACKAGE

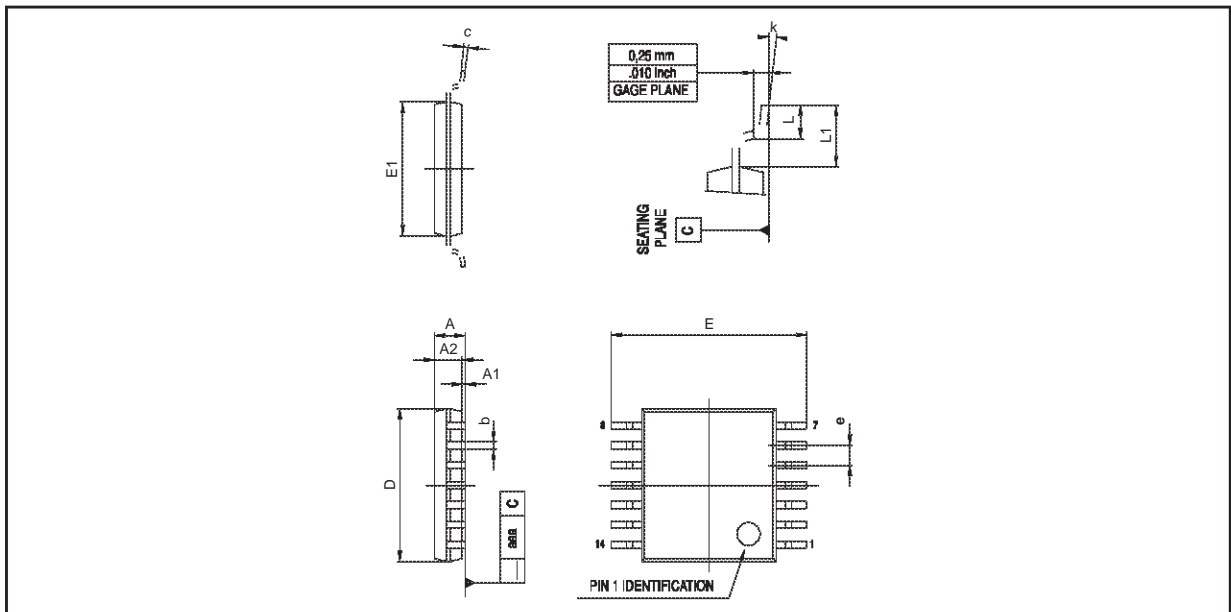

| Dim. | Millimeters | | | Inches | | |
|------|-------------|------|------|--------|--------|-------|
| | Min. | Typ. | Max. | Min. | Typ. | Max. |
| A | | | 1.20 | | | 0.05 |
| A1 | 0.05 | | 0.15 | 0.01 | | 0.006 |
| A2 | 0.80 | 1.00 | 1.05 | 0.031 | 0.039 | 0.041 |
| b | 0.19 | | 0.30 | 0.007 | | 0.15 |
| c | 0.09 | | 0.20 | 0.003 | | 0.012 |
| D | 4.90 | 5.00 | 5.10 | 0.192 | 0.196 | 0.20 |
| E | | 6.40 | | | 0.252 | |
| E1 | 4.30 | 4.40 | 4.50 | 0.169 | 0.173 | 0.177 |
| e | | 0.65 | | | 0.025 | |
| k | 0° | | 8° | 0° | | 8° |
| l | 0.50 | 0.60 | 0.75 | 0.09 | 0.0236 | 0.030 |

TS861ILT

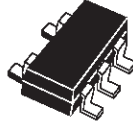

PACKAGE MECHANICAL DATA
5 PINS - TINY PACKAGE (SOT23)

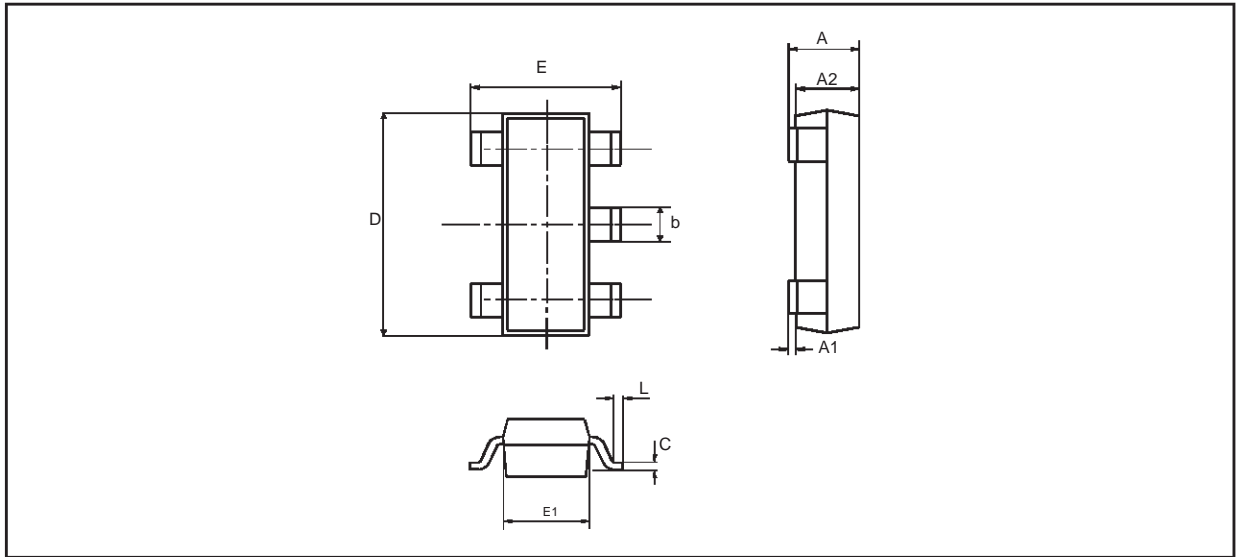

| Dim. | Millimeters | | | Inches | | |
|------|-------------|------|------|--------|-------|--------|
| | Min. | Typ. | Max. | Min. | Typ. | Max. |
| A | 0.90 | 1.20 | 1.45 | 0.035 | 0.047 | 0.057 |
| A1 | 0 | | 0.15 | | | 0.006 |
| A2 | 0.90 | 1.05 | 1.30 | 0.035 | 0.041 | 0.051 |
| B | 0.35 | 0.40 | 0.50 | 0.014 | 0.016 | 0.020 |
| C | 0.09 | 0.15 | 0.20 | 0.004 | 0.006 | 0.008 |
| D | 2.80 | 2.90 | 3.00 | 0.110 | 0.114 | 0.118 |
| D1 | | 1.90 | | | 0.075 | |
| e | | 0.95 | | | 0.037 | |
| E | 2.60 | 2.80 | 3.00 | 0.102 | 0.110 | 0.0118 |
| F | 1.50 | 1.60 | 1.75 | 0.059 | 0.063 | 0.069 |
| L | 0.10 | 0.5 | 0.60 | 0.004 | 0.014 | 0.024 |
| K | 0d | | 10d | 0d | | 10d |

Information furnished is believed to be accurate and reliable. However, STMicroelectronics assumes no responsibility for the consequences of use of such information nor for any infringement of patents or other rights of third parties which may result from its use. No license is granted by implication or otherwise under any patent or patent rights of STMicroelectronics. Specifications mentioned in this publication are subject to change without notice. This publication supersedes and replaces all information previously supplied. STMicroelectronics products are not authorized for use as critical components in life support devices or systems without express written approval of STMicroelectronics.

© The ST logo is a registered trademark of STMicroelectronics

© 2000 STMicroelectronics - Printed in Italy - All Rights Reserved
STMicroelectronics GROUP OF COMPANIES

Australia - Brazil - China - Finland - France - Germany - Hong Kong - India - Italy - Japan - Malaysia - Malta - Morocco
Singapore - Spain - Sweden - Switzerland - United Kingdom

© <http://www.st.com>

