



QuickSaver® Charge Controller for Nickel-Cadmium and Nickel-Metal Hydride Batteries

General Description

The ICS1702 is a CMOS device designed for the intelligent charge control of either nickel-cadmium (NiCd) or nickel-metal hydride (NiMH) batteries. The controller uses a pulsed-current charging technique together with voltage slope and/or temperature slope termination. The ICS1702 employs a four stage charge sequence that provides a complete recharge with-out overcharging. The controller has nine user-selectable charge rates and six user-selectable auxiliary modes available for customized charging systems.

The ICS1702 monitors for the presence of a battery and begins charging when a battery is installed. Voltage and temperature are measured to ensure a battery is within fast charge conditions before charge is initiated.

Applications

Battery charging systems for:

- Portable consumer electronics
- Power tools
- Audio/video equipment
- Communications equipment
- Portable medical electronics
- Wireless handsets

Features

- Multiple charge termination methods include:
 - Voltage slope
 - Temperature slope
 - Maximum temperature
 - Charge timer
- Four stage charge sequence:
 - Soft start charge
 - Fast charge
 - Topping charge
 - Maintenance charge
- Reverse-pulse charging available in all charge stages
- Nine programmable charge rates between 15 minutes (4C) and four hours (C/4)
- Out-of-temperature range detection
 - Hot battery: charger shutdown
 - Cold battery: low current charge
- Continuous polling mode for battery detection
- Six auxiliary modes include:
 - Discharge-before-charge
 - Ten hour C/10 conditioning charge
 - Direct to C/40 maintenance charge
 - Charging system test provided through controller
- Adjustable open circuit (no battery) voltage reference

Block Diagram

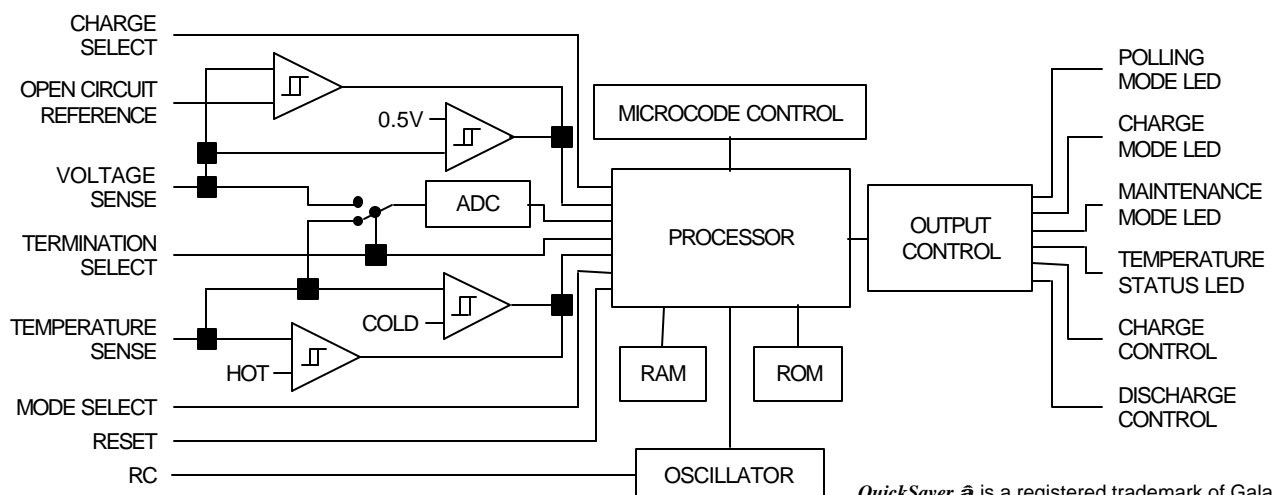

QuickSaver® is a registered trademark of Galaxy Power, Inc.

ICS1702



Pin Configuration

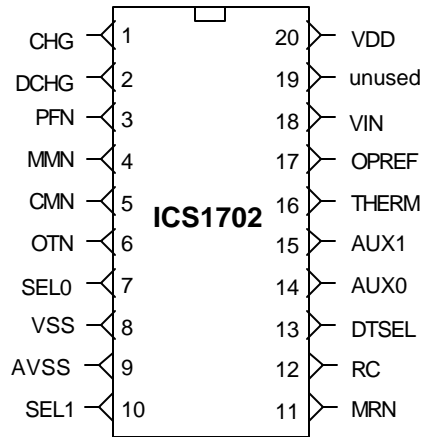

20-Pin DIP or SOIC

Pin Definitions

Pin Number	Pin Name	Type	Definition
1	CHG	OUT	Active high TTL compatible signal used to turn on an external current source to provide current to charge the battery.
2	DCHG	OUT	Active high TTL compatible signal available to turn on a discharge circuit.
3	PFN	OUT	Polling detect indicator. An active low turns on an external indicator to show the controller is polling for the presence of the battery.
4	MMN	OUT	Maintenance mode indicator. An active low turns on an external indicator showing the battery is either in the topping charge, maintenance charge or auxiliary condition mode. This signal is also applied with the out-of-temperature range indicator when the controller is in a cold battery charge mode. The indicator flashes during the auxiliary discharge mode.
5	CMN	OUT	Charge mode indicator. An active low turns on an external indicator to show the controller is either in a soft start charge or fast charge.
6	OTN	OUT	Out-of-temperature range indicator. An active low turns on an external indicator showing the battery is out of the normal fast charge temperature range.
7	SEL0	IN	Tri-level input used with the SEL1 pin to program the device for the desired charge rate.
8	VSS		Ground.
9	AVSS		Ground.
10	SEL1	IN	Tri-level input used with the SEL0 pin to program the device for the desired charge rate.
11	MRN	IN	Master reset signal. A logic low pulse greater than 700 ms initiates a device reset.
12	RC	IN	An external resistor and capacitor sets the frequency of the internal clock.
13	DTSEL	IN	Selects temperature slope and/or voltage slope termination.
14	AUX0	IN	Tri-level input used with the AUX1 pin to program the device for an auxiliary operating mode.
15	AUX1	IN	Tri-level input used with the AUX0 pin to program the device for an auxiliary operating mode.
16	THERM	IN	Thermistor or thermal switch input for temperature sensing.
17	OPREF	IN	Open circuit (no battery) voltage reference. An external resistor divider on this pin sets the open circuit voltage reference used to detect the presence of a battery.
18	VIN	IN	Battery voltage normalized to one cell with an external resistor divider.
19	unused		Ground.
20	VDD		Device supply =+5.0 VDC

Note: Pin 11 has an internal pull-up.
 Pin 16 has an internal pull-up.
 Pin 13 has an internal pull-down.
 Pins 7, 10, 14, 15 float to 2.3V when unconnected.



Controller Operation

Charging Stages

The charging sequence consists of four stages. The application of current is shown graphically in Figure 1. The soft start stage gradually increases current levels up to the user selected fast charge rate during the first two minutes. The soft start stage is followed by the fast charge stage, which continues until termination. After termination, a two hour C/10 topping charge is applied. The topping charge is followed by a C/40 maintenance charge.

Soft Start Charge

Some batteries may exhibit an unusual high impedance condition while accepting the initial charging current, as shown in Figure 2. Unless dealt with, this high impedance condition can cause a voltage peak at the beginning of the charge cycle that would be misinterpreted as a fully charged battery by the voltage termination methods.

The soft start charge eases batteries into the fast charge stage by gradually increasing the current to the selected fast charge rate. The gradual increase in current alleviates the voltage peak. During this stage, only positive current pulses are applied to the battery. The duty cycle of the applied current is increased to the selected fast charge rate, as shown in Figure 3, by extending the current pulse on every cycle until the pulse is about one second in duration. The initial current pulse is approximately 200ms. The CMN indicator is activated continuously during this stage.

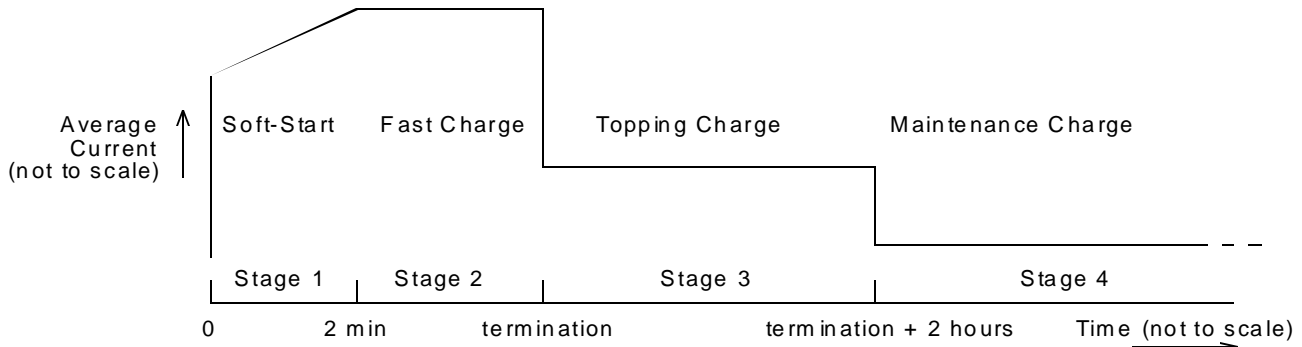

Figure 1: Graphical representation of average current levels during the four charging stages

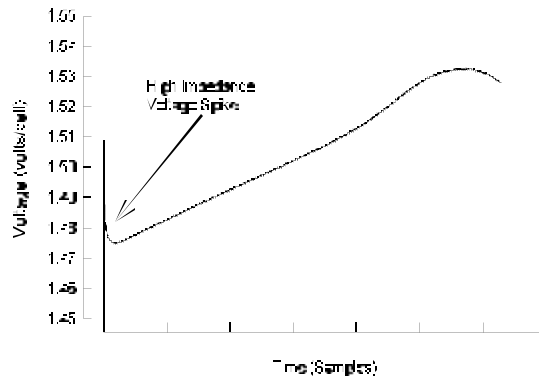

Figure 2: High impedance voltage spike at the beginning of charge

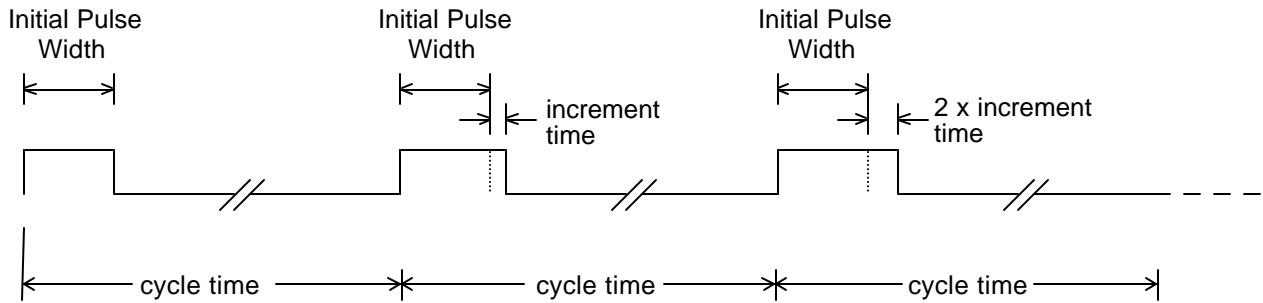

Figure 3: Cycle-to-cycle increase of the soft-start current pulse widths

Fast Charge

In the second stage, the **ICS1702** applies the charging current in a series of charge and discharge pulses. The technique consists of a positive current charging pulse followed by a high current, short duration discharge pulse. The cycle, shown with charge, discharge, rest and data acquisition periods in Figure 4, repeats every second until the batteries are fully charged.

The amplitude of the current pulse is determined by system parameters such as the current capability of the charging system, the desired charge rate, the cell capacity and the ability of that cell to accept the charge current. The **ICS1702** can be set for nine user-selectable fast charge rates from 15 minutes (4C) to four hours (C/4). Charge pulses occur approximately every second. The CMN indicator is activated continuously during this stage.

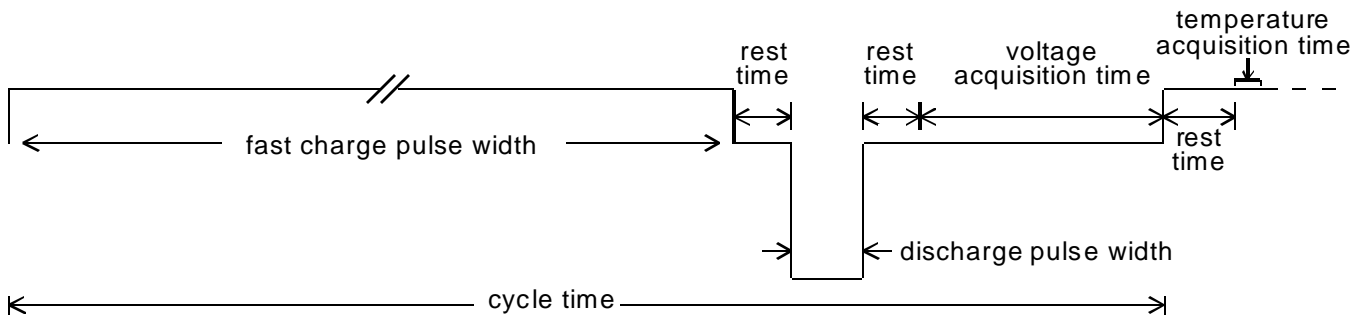

Figure 4: Charge cycle showing charge and discharge current pulses



The discharge current pulse amplitude is typically set to about 2.5 times the amplitude of the charging current based on 1.4V/cell. For example, if the charge current is 4 amps, then the discharge current is set at about 10 amps. The energy removed during the discharge pulse is a fixed ratio to the positive charge rate. The amplitude of the discharge pulse does not affect the operation of the part as described in this section.

A voltage acquisition window immediately follows a brief rest time after the discharge pulse. No charge is applied during the rest time or during the acquisition window to allow the cell chemistry to settle. Since no current is flowing, the measured cell voltage is not obscured by any internal or external IR drops or distortions caused by excess plate surface charge. The **ICS1702** makes one continuous reading of the no-load battery voltage during the entire acquisition window. The voltage that is measured during this window contains less noise and is a more accurate representation of the true state of charge of the battery. If temperature termination is selected, the thermistor voltage is sampled after a brief rest time once the current supply to the battery is turned on.

Topping Charge

The third stage is a topping charge that applies current at a rate low enough to prevent cell heating but high enough to ensure a full charge.

The topping charge applies a C/10 charging current for two hours. The current consists of the same pulse technique used during the fast charge stage; however, the duty cycle of the pulse sequence has been extended as shown in Figure 5. Extending the time between charge pulses allows the same charging current used in the fast charge stage so that no changes to the current source are necessary. For example, the same charge pulse that occurs every second at a 2C fast charge rate will occur every 20 seconds for a topping charge rate of C/10. The MMN indicator is activated continuously during this stage.

Maintenance Charge

The maintenance charge is intended to offset the natural self-discharge of NiCd or NiMH batteries by keeping the cells primed at peak charge. After the topping charge ends, the **ICS1702** begins this charge stage by extending the duty cycle of the applied current pulses to a C/40 rate. The maintenance charge will last for as long as the battery voltage is greater than 0.5V at the VIN pin, or, if the ten hour timer mode is enabled, until the timer stops the controller. The MMN indicator is activated continuously during this stage.

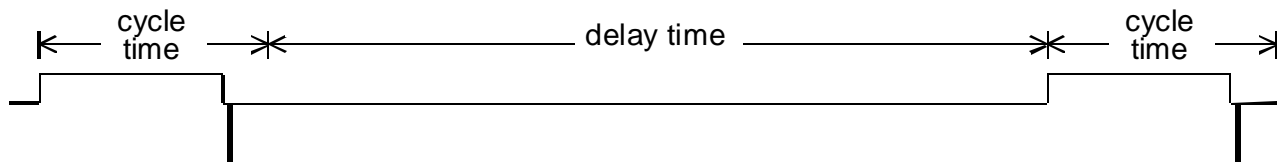

Figure 5: Representative timing diagram for topping and maintenance charge



Charge Termination Methods

Several charge termination schemes, including voltage slope, temperature slope, maximum temperature and two overall charge timers are available. The voltage slope and negative voltage slope methods may be used with or without the temperature slope and the maximum temperature method. Maximum temperature and the fast charge timer are available as backup methods.

Voltage Slope Termination

The most distinctive point on the voltage curve of a charging battery in response to a constant current is the voltage peak that occurs as the cell approaches full charge. By mathematically calculating the first derivative of the voltage, a second curve can be generated showing the change in voltage with respect to time as shown in Figure 6. The slope will reach a maximum just before the actual peak in the cell voltage. Using the voltage slope data, the ICS1702 calculates the point of full charge and accurately terminates the applied current as the battery reaches that point. The actual termination point depends on the charging characteristics of the particular battery.

Cells that are not thoroughly conditioned or possess an unusual cell construction may not have a normal voltage profile. The ICS1702 uses an alternate method of charge termination based on a slight decrease in the voltage slope to stop charge to cells whose voltage profile is very shallow. This method looks for a flattening of the voltage slope which may indicate a shallow peak in the voltage profile. The zero slope point occurs slightly beyond the peak voltage and is shown on the voltage curve graph.

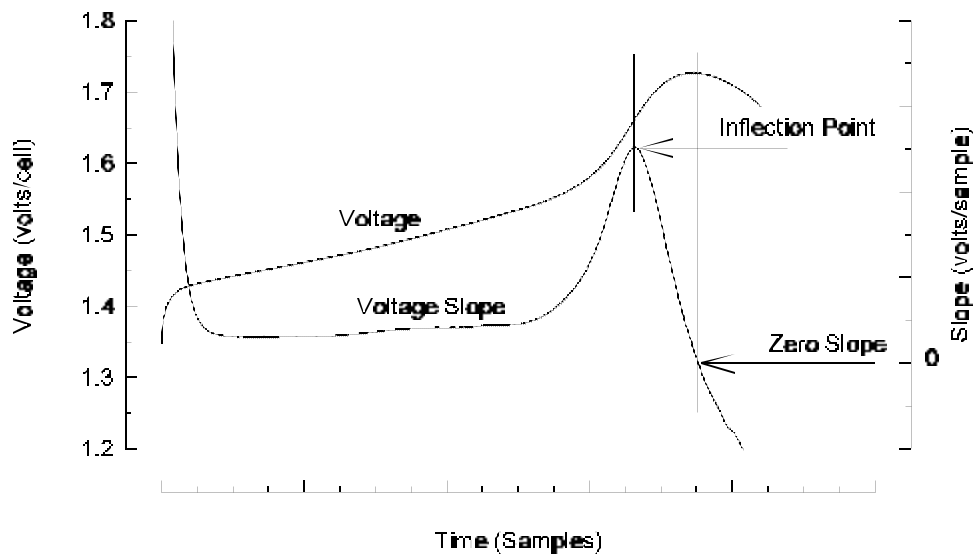

Figure 6: Voltage and slope curves showing inflection and zero slope points



Temperature Slope Termination

Temperature slope termination is based on the battery producing an accelerated rate of heating as the amount of readily chargeable material diminishes at full charge. An increase in battery (cell) heating due to the charging reaction will occur at a much faster rate than a change due to a warming ambient temperature. Note the effect of 0.5°C fluctuations in ambient temperatures resulting in slight variations in the temperature slope as shown in Figure 7. However, the increase in cell temperature near the end of charge causes a much larger change in the temperature slope that can be easily detected and used as a trigger for fast charge termination.

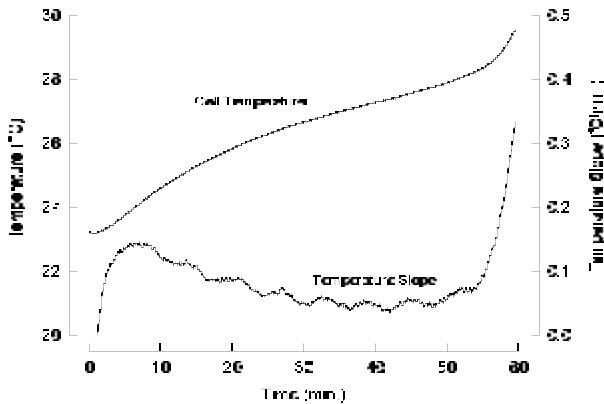

Figure 7: Cell temperature and temperature slope

The rate of change in cell temperature can be determined by measuring the change in voltage across a negative temperature coefficient thermistor as shown in Figure 8. The resistance of an NTC thermistor changes in proportion in the change in temperature of the thermistor. The ICS1702 measures the decreasing resistance as a drop in voltage and calculates the thermistor voltage slope, shown in Figure 8. The controller terminates fast charge based on the selected charge rate and the calculated slope.

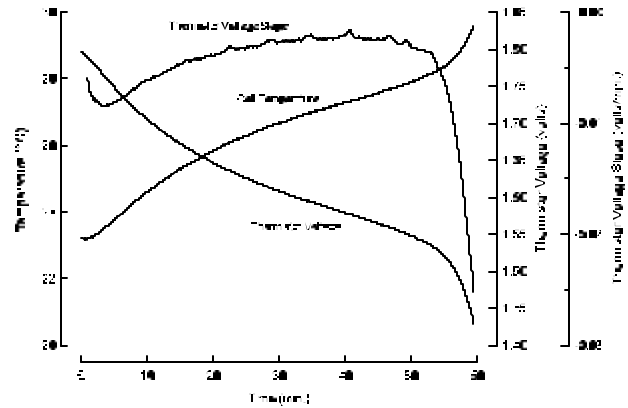

Figure 8: Cell temperature and thermistor voltage slope

Table 1 shows the decrease in thermistor voltage the last minute before full charge required by the ICS1702 at various charge rates. The thermistor voltage slope should exceed the listed value to ensure charge termination. Note that changes in thermistor location, cell size or large ambient temperature fluctuations can affect the slope to some degree. Refer to the *Applications Information* section and *Temperature Slope and Maximum Temperature* section for more information on thermistor mounting.

Table 1: Slope vs. Charge Rate

Charge Rate	Thermistor Voltage Slope (-V/min.)
>C/2	0.040
C/2 to C/3	0.028
<C/3	0.018



To determine the required thermistor characteristics for proper temperature slope termination, the battery temperature rise must be known or determined for the last minute prior to full charge.

Maximum temperature termination is also enabled when temperature slope termination is used. Care must be taken to keep voltage levels at the THERM pin within the fast charge range (between 2.4V and 0.93V), as shown in Figure 9.

Maximum Temperature Termination

Maximum temperature can be sensed using either a NTC thermistor or a thermal switch. Maximum temperature termination can also be bypassed if desired, although it is strongly recommended that some form of temperature termination be used.

If an NTC thermistor is used, an internal voltage threshold determines when the battery is too hot to charge. As temperature increases, the voltage across the thermistor will drop. This voltage is continually compared to the internal voltage threshold. If the thermistor voltage drops below the internal threshold, the OTN indicator is activated and the controller shuts down. The controller must be reset once the hot battery fault condition has cleared to restart the charge sequence.

If a thermal switch is used, a 45°C open circuit switch is recommended. When the thermal switch opens, an internal pull-up at the THERM pin results in a logic high which shuts down the controller and activates the OTN indicator. The controller must be reset once the hot battery fault condition has cleared to restart the charge sequence.

Maximum temperature termination can be disabled by grounding the THERM pin. See the section on *Temperature Sensing* for more information.

Fast Charge Timer Termination

The controller uses a timer to limit the fast charge duration.

These times are pre-programmed, and are automatically adjusted in time duration according to the charge rate selected. Fast charge timer termination is best suited as a safety backup feature to limit the duration of the fast charge stage. The fast charge timer is always enabled and cannot be disabled. See Table 4 in the section *Charge Rate Selection* for more information.



Battery Detection

Upon power-up or after a master reset, excess charge from output filter capacitors at the charging system terminals is removed with a series of discharge pulses. After the discharge pulse sequence is complete, the voltage at VIN must be greater than 0.5V when a battery is present. If the voltage at the pin is less than 0.5V, the **ICS1702** assumes no battery is present, and the polling detect mode is initiated. No indicator is active during the discharge pulses.

The **ICS1702** enters the polling detect mode and applies a 100ms charge pulse. During the pulse, the **ICS1702** monitors the VIN pin to determine if the divided down terminal voltage is above OPREF. If the battery is present, the voltage will be clamped below the reference on OPREF while the current pulse is applied. If a battery is not present, the voltage at VIN will rise above the reference at OPREF.

The charge pulse will repeat until the battery is reinstalled. The polling detect indicator (PFN) is the only indicator active as long as the **ICS1702** is in the polling detect mode. Once a battery is installed, the **ICS1702** will turn off the PFN indicator and enter the soft start stage. The **ICS1702** will automatically reenter the polling detect mode if the battery is removed.

Battery Removal

During the application of a charge pulse, the voltage at the VIN pin is compared to the voltage at the OPREF pin. If the voltage at VIN is greater than the voltage at OPREF during the application of the current pulse, then the battery is assumed to have been removed and the **ICS1702** enters the polling detect mode. If the voltage at VIN is below the voltage at OPREF, the charging mode continues.

When in the topping charge or maintenance charge stages, a charge pulse may not occur for several seconds. During the period between charge pulses, the voltage at VIN must be greater than 0.5V if a battery is attached. If the voltage at VIN is less than 0.5V, the **ICS1702** assumes the battery has been removed, and the polling detect mode is initiated.

Auxiliary Modes of Operation

The **ICS1702** allows six alternate modes of operation to help customize the charging system for certain applications. The tri-level AUX0 and AUX1 pins are used to select the operating mode. The AUX0 and AUX1 pins default the **ICS1702** into fast charge operation. Except for the discharge-to-charge mode, another mode can only be selected by re-programming and resetting the controller.

Discharge-to-Charge Mode

The time required for discharge depends on the energy in the battery and the discharge rate. The discharge is not limited by a timer. This allows the user to set the discharge rate. The battery is drained to 1 volt/cell as read at the VIN pin under load and then the controller enters soft start at a charge rate set by the SEL0 and SEL1 inputs. The discharge load is activated by the DCHG pin which goes low for about 400ms every second. A resistor value selected for a 2.5C discharge based on 1.4V/cell results in about a 1C discharge rate.

The discharge-to-charge mode can be entered by placing the AUX0 pin high (H) and the AUX1 pin low (L) with the SEL0 and SEL1 inputs set for the desired fast charge rate. This setting initializes the discharge sequence. The **ICS1702** enters the discharge-to-charge mode at initial power-up or with a master reset. The discharge mode occurs first, to be followed by the selected fast charge mode. During discharge, the MMN indicator flashes at a one second rate, while during the soft start and fast charge stages the CMN indicator is activated continuously.

Four charge modes are available after the discharge portion is complete by changing the state of the AUX inputs during the discharge portion of this mode. The available charge modes are:

- Fast Charge: Leave the AUX inputs open (Z).
- Direct Maintenance Mode: Set the AUX0 low (L) and AUX1 high (H).
- Condition Mode: Set AUX0 high (H) and AUX1 open (Z).
- Ten-Hour Timer Mode: Set AUX0 high (H) and AUX1 high (H).

If the battery is removed while in the discharge-to-charge mode, the **ICS1702** will continually reset itself until the battery is reinstalled. See *Application Information* for more information.

Discharge-Only Mode

The time required for discharge depends on the energy in the battery and the discharge rate. The discharge is not limited by a timer. This allows the user to set the discharge rate. The battery is drained to 1 volt/cell as read at the VIN pin under load. The **ICS1702** shuts down after the discharge sequence is finished and a master reset must be performed to reactivate the device. The discharge load is activated by the DCHG pin which goes low for about 400ms every second. A resistor value selected for a 2.5C discharge based on 1.4V/cell results in about a 1C discharge rate. The discharge-only mode can be entered by placing the AUX0 pin open (Z) and the AUX1 pin low (L). The **ICS1702** enters this mode at initial power-up or with a master reset. During the discharge portion, the MMN indicator flashes at a one second rate.

ICS1702



Direct Maintenance Mode

The **ICS1702** can enter directly into the C/40 maintenance mode for cells that require a maintenance charge only. The direct maintenance mode is activated by setting the AUX0 pin low (L) and the AUX1 pin high (H), and resetting the device. The SEL0 and SEL1 pins must be set based on the charging current and the battery capacity. The formula

Charging Current (Amps)

Battery Capacity (Amp • hr)

gives the charge rate. Use Table 4 to find the correct SEL0 and SEL1 settings. The maintenance charge is applied until the battery is removed, upon which the **ICS1702** will enter the polling detect mode. The **ICS1702** will enter the direct maintenance mode upon initial power-up or after a master reset. The MMN indicator will be active during this mode.

Conditioning Mode

The **ICS1702** can enter a conditioning mode which applies a C/10 charge for a timed 10 hour period, followed by an indefinite C/40 maintenance charge until the batteries are removed.

The conditioning mode can be entered by setting the AUX0 pin high (H) and the AUX1 pin open (Z). The SEL0 and SEL1 pins must be set based on the charging current and the battery capacity. The formula

Charging Current (Amps)

Battery Capacity (Amp • hr)

gives the charge rate. Use Table 4 to find the correct SEL0 and SEL1 settings. The MMN indicator will be active during the 10 hour conditioning charge and the maintenance charge that follows. The **ICS1702** enters the polling detect mode if the battery is removed.

Ten Hour Timer Mode

Placing the AUX0 and AUX1 pins both high (H) enables a ten hour timer. This timer limits the total charge, including the maintenance charge, to approximately ten hours for a battery that is completely discharged before fast charge is initiated. The ten hour limit is based on the assumption that the charge terminates due to the fast charge timer as shown in Table 2

Charging System Test

The system test mode is intended for use in applications where the charging system functionality needs to be tested. The system test sequence consists of a one second activation of the CMN, MMN and PFN indicator pins as well as the CHG and DCHG lines. The OTN indicator is not activated. The system test mode is entered by placing both the AUX0 and AUX1 pins low (L). The **ICS1702** shuts down after the test sequence is finished and a master reset must be performed to reactivate the device.

Cold Battery Charging

Cold battery charging is activated if a voltage at the THERM pin is in the cold battery voltage range, as shown in Figure 9. The **ICS1702** checks for a cold battery before initiating fast charge. If a cold battery is present before fast charge begins, the **ICS1702** begins a two-hour C/10 topping charge (the pulsed duty cycle is based on the selected charge rate). If the battery is still cold after the two hour topping charge is complete, the **ICS1702** begins a C/40 maintenance charge. The maintenance charge will continue for as long as the battery remains cold Unless the ten hour time mode is selected. The thermistor voltage at the THERM pin is checked every second to see if the battery has warmed up. If so, the **ICS1702** stops the topping or maintenance charge and begins a fast charge at a rate selected by the SEL0 and SEL1 inputs. A cold battery does not interfere with the condition mode, direct maintenance mode, the discharge portion of the discharge-to-charge mode, or the discharge-only mode as programmed by the AUX0 and AUX1 pins. See the section on *Temperature Sensing*, for more information.

The MMN and OTN indicators will be active, indicating that a low current charge is being applied to a battery that is outside the specified temperature range for fast charging. If the CMN and OTN indicators are active see the *Application Information* section.

Table 2: Ten Hour Timer Information

Charge Rate	Fast Charge Timer Cutoff	Maintenance Timer Cutoff (after fast charge termination)	Charge Time Limit (from reset)
4 C	0.3 hrs	9.7 hrs	10 hrs
2 C	0.6 hrs	9.4 hrs	10 hrs
1.3 C	0.9 hrs	9.1 hrs	10 hrs
1 C	1.2 hrs	8.8 hrs	10 hrs
C/1.5	1.8 hrs	8.2 hrs	10 hrs
C/2	2.4 hrs	7.6 hrs	10 hrs
C/2.5	3.5 hrs	6.5 hrs	10 hrs
C/3	4.0 hrs	6.0 hrs	10 hrs
C/4	4.6 hrs	5.4 hrs	10 hrs



Pin Descriptions

The **ICS1702** requires some external components to control the clock rate, sense temperature and provide an indicator display. The controller must be interfaced to an external power source that will provide the current required to charge a battery pack and, if desired, a circuit that will sink discharge current.

Output Logic Signals: CHG, DCHG Pins

The CHG and DCHG pins are active high, TTL compatible outputs. In addition to being TTL compatible, the CMOS outputs are capable of sourcing current which adds flexibility when interfacing to other circuitry. A logic high on the CHG pin indicates that the charging current supply should be activated. If applicable, a logic high on the DCHG pin indicates that the discharge circuit should be activated.

Care must be taken to control wiring resistance and inductance. The load resistor must be capable of handling this short duration high-amplitude pulse. If the auxiliary discharge-to-charge mode is selected, the power dissipation of the load resistor must be properly selected to accept the extended length of the discharge pulse.

Indicators: CMN, MMN, PFN, OTN Pins

The controller has four outputs for driving external indicators. These pins are active low. The four indicator outputs have open drains and are designed to be used with LEDs. Each output can sink over 20mA which requires the use of an external current limiting resistor. The four indicator signals denote fast charge stage, topping and maintenance stages, and the polling detect and out-of-temperature range modes as shown in Table 3.

The charge mode (CMN) indicator is activated continuously during the soft start and fast charge stages. When the controller enters the topping charge stage, the output goes high and the indicator turns off.

The maintenance mode (MMN) indicator is on when the **ICS1702** is either in the topping charge, maintenance charge, direct maintenance mode, or the condition mode. The MMN indicator is also lit in conjunction with the OTN indicator when cold battery charging is in progress. The maintenance mode indicator flashes at a one second rate when the **ICS1702** is controlling the discharge portion of the discharge-to-charge or the discharge-only mode.

The polling detect (PFN) indicator is on when the **ICS1702** polls for a battery. The controller applies periodic charge pulses to detect the presence of a battery. The indicator is a warning that these charge pulses are appearing at the charging system terminals at regular intervals. When a battery is detected, the indicator is turned off.

The out-of-temperature range (OTN) indicator is active whenever the voltage at the temperature sense (THERM) input enters a range that indicates that the attached battery is too hot to charge. The OTN indicator is also activated with the MMN indicator if the controller is initialized with the battery in the cold battery charge region.

Charge Rate Selection: SEL0, SEL1 Pins

The SEL0 and SEL1 inputs must be programmed by the user to inform the **ICS1702** of the desired charge rate. When left unconnected (open), these tri-level pins will float to about 2.3V. When a low level is required, the pin must be grounded. When a high level is required, the pin must be tied to V_{DD} . The voltage ranges for low (L), open (Z) and high (H) are listed in Table 10, *DC Characteristics*. To program the SEL0 and SEL1 inputs, refer to the *Charge Rate List* in Table 4.

The **ICS1702** does not control the current flowing into the battery in any way other than turning it on and off. The required current for the selected charge rate must be provided by the user's power source. The external charging circuitry should provide current at the selected charge rate. For example, to charge a 1.2 ampere hour battery in 30 minutes (2C), approximately 2.4 amperes of current is required.

Table 3: Indicator Description List

PFN	MMN	CMN	OTN	Description
on				Polling detect mode
	on			Maintenance or topping charge, direct maintenance or condition mode
		on		Fast Charge
			on	Hot battery shutdown
	on		on	Cold Battery Charge
	flash			Discharge portion of the discharge-to-charge or discharge-only mode
		flash		see Applications Information
		on	on	see Applications Information
	flash	flash		see Applications Information
	flash		on	see Applications Information



Table 4: Charge Rate List

SEL0	SEL1	Charge Rate	Topping Charge pulse Rate	Maintenance Charge Pulse Rate	Fast Charge Timer Duration (after reset)
L	L	4C (15 min)	one every 40 sec	one every 160 sec	21 min
L	H	2C (30 min)	one every 20 sec	one every 80 sec	39 min
L	Z	1.3C (45 min)	one every 13 sec	one every 53 sec	57 min
H	L	1C (60 min)	one every 10 sec	one every 40 sec	75 min
H	Z	C/1.5 (90 min)	one every 7 sec	one every 27 sec	110 min
H	H	C/2 (120 min)	one every 5 sec	one every 20 sec	144 min
Z	L	C/2.5 (150 min)	one every 4 sec	one every 16 sec	212 min
Z	Z	C/3 (180 min)	one every 3 sec	one every 13 sec	244 min
Z	H	C/4 (240 min)	one every 2 sec	one every 10 sec	275 min

See the section on *Controller Operation* for additional information on the topping charge and maintenance charge. See the section on *Charge Termination Methods* for additional information on the charge timer.

Mode Selection: AUX0, AUX1 Pins

The AUX0 and AUX1 inputs must be programmed by the user to inform the **ICS1702** of the desired auxiliary mode. When left unconnected (open) these tri-level pins will float to about 2.3V. When a low level is required, the pin must be grounded.

When a high level is required, the pin must be tied to V_{DD} . The voltage ranges for low (L), open (Z) and high (H) are listed in Table 10, *DC Characteristics*. To program the AUX0 and AUX1 inputs, refer to the Mode Select List in Table 5. See the section on Auxiliary Modes of Operation for additional information.

Table 5: Mode Select List

AUX0	AUX1	Mode Selected	Mode Operation
L	L	Charging System Test	Charging system test for embedded applications
L	H	Direct Maintenance	Indefinite C/40 maintenance charge
Z	Z	Fast Charge	Default
Z	L	Discharge-Only	Battery discharge to 1V/cell
H	L	Discharge-to-Charge	Battery discharge to 1V/cell followed by the selected charge mode
H	Z	Condition	Timed C/10 topping charge followed by a C/40 maintenance charge
H	H	Ten Hour Timer	Limits total charge including the maintenance charge to 10 hours



Master Reset: MRN Pin

The MRN pin is provided to re-program the controller for a new mode or charging sequence. This pin has an internal pull-up of about 75kΩ. A logic low on the MRN pin must be present for more than 700ms for a reset to occur. As long as the pin is low, the controller is held in a reset condition. A master reset is required to clear a temperature fault condition, clear the charging system test, reset the ten hour timer or change charge rates or auxiliary modes. Upon power-up, the controller automatically resets itself.

Clock Input: RC Pin

The RC pin is used to set the frequency of the internal clock when an external 1 MHz clock is not available. An external resistor must be connected between this pin and VDD. An external capacitor must be connected between this pin and ground. The frequency of the internal clock will be about 1 MHz with a 16kΩ resistor and a 100pF capacitor. All time durations noted in this document are based on a 1 MHz clock. Operating the clock at a lower frequency will proportionally change all time durations. Operating the clock at a frequency significantly lower than 1 MHz, without adjusting the charge current accordingly, will lessen the effectiveness of the fast charge timer and lower the accuracy of the controller. Operating the clock at a frequency greater than 1 MHz will also change all time durations and, without adjusting the charge current accordingly, may cause termination to occur due to the fast charge timer expiring rather than by the battery reaching full charge.

The clock may be driven by a 1 MHz external 0 to 5V pulse provided the duty cycle is between 10% and 60%. The clock input impedance is about 1kΩ.

Temperature Sensing: THERM Pin

The THERM pin is provided for hot and cold battery detection and for temperature slope termination of fast charge when used in conjunction with an NTC thermistor. The THERM pin also provides for hot battery and maximum temperature termination when used in conjunction with a normally closed thermal switch. Several internal voltage thresholds are used by the controller depending on whether a thermistor or a thermal switch is used. Figure 9 shows the internal thresholds over laid on a typical thermistor curve.

- Using an NTC thermistor for hot and cold battery detection:

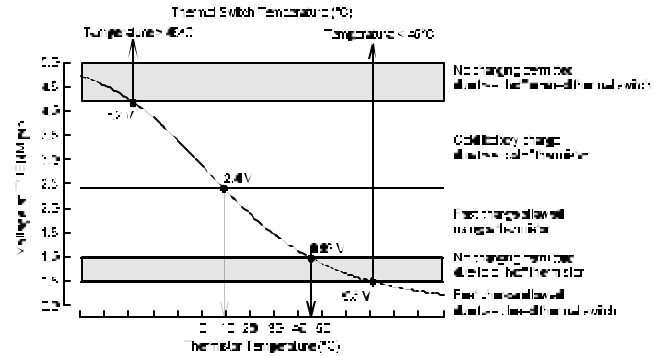

Figure 9: Voltage levels for temperature sensing with a thermistor or thermal switch

The THERM pin requires some thought if a thermistor is going to be used for hot and cold battery detection. The example below works for a typical 10kΩ @ 25°C NTC thermistor. Consider using the controller to prevent charging above 45°C and reducing the current below 10°C. At 10°C the resistance of the thermistor is 18kΩ. At 45°C, the resistance drops to 4.7kΩ. The ICS1702 has an internal voltage threshold at 10°C at 2.4V, and an internal voltage at 45°C at 0.93V as shown in Figure 9. At 25°C the voltage at the THERM pin is set at the midpoint of the thresholds:

$$0.93V + \frac{2.40V - 0.93V}{2} = 1.67V.$$

The THERM pin has a 75kΩ internal pull-up (R_{pu}). Using a resistor divider with 10kΩ for the thermistor (R_{th}) and a external fixed resistor (R_{fix}), the divider looks like Figure 8 at 25°C:

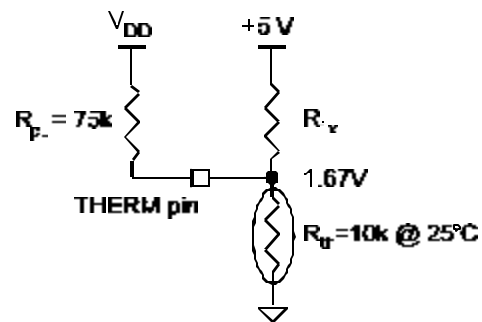

Figure 10: Voltage divider at the THERM pin at 25°C



ICS1702

To set the voltage at the THERM pin for 1.67V at 25°C, the equivalent divider looks like Figure 11.

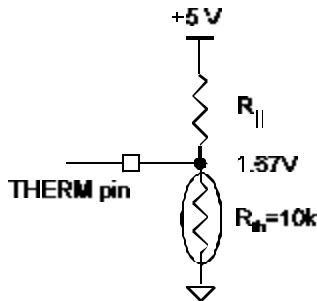

Figure 11: Equivalent voltage divider

The parallel resistance $R_{||}$ is calculated:

$$R_{||} = \frac{5V - 1.67V}{1.67V/10k\Omega} = 20k\Omega.$$

The internal pull-up resistance R_{pu} and the parallel resistance $R_{||}$ are known so the external fixed resistor can be calculated from:

$$R_{fix} = \frac{R_{pu} R_{||}}{R_{pu} - R_{||}}.$$

Substituting in known values: $R_{fix} = 27.27k\Omega$. A $27k\Omega$ standard value is used for R_{fix} .

Since the thermistor resistance R_{th} is specified by manufacturers at a particular temperature, the voltage across the thermistor V_{th} at that temperature can be calculated from:

$$V_{th} = \frac{R_{th} (5V)}{R_{pu} + R_{||}} (5V),$$

with the drop across the resistor divider equal to 5V. For this example, the calculated voltage with $R_{th}=18k\Omega$ at $10^\circ C$ is 2.37V and with $R_{th}=4.7k\Omega$ at $45^\circ C$ the voltage is 0.95V. Table 6 lists the internal thresholds for hot and cold battery detection. If the voltage across the thermistor (at the THERM pin) drops below 0.93V, the ICS1702 will shut down due to a hot battery fault condition and will not restart unless reset. If the voltage dropped across the thermistor is above 2.4V before fast charge is initiated, the ICS1702 will begin a reduced current charge. See the *Cold Battery Charging* section for more information.

Table 6: Thermistor Voltage Thresholds

Parameter	Voltage	Battery Temperature
Cold Battery Thermistor Voltage	>2.4	<10°C
Hot Battery Thermistor Voltage	<0.93	>45°C

- Using an NTC thermistor for temperature slope termination:

As a battery approaches full charge, its accelerated rate of heating can be used to terminate fast charge by detecting the large change in the temperature slope. The large change in temperature slope is proportional to the thermistor voltage change per unit of time. If the DTSEL pin is programmed for temperature slope termination, the controller will calculate the thermistor voltage slope and terminate based on internally set thresholds as listed in Table 1. The threshold is 40mV per minute for selected charge rates greater than C/2, 28mV per minute for charge rates selected at or between C/2 and C/3, and 18mV per minute for selected charge rates less than C/3. The voltage across the thermistor must change at these rates or greater to terminate the selected charge rate.

These thresholds correspond to a set change in thermistor resistance when an external pull-up to 5V is used as shown in Figure 11. Using the values calculated from the hot and cold battery detection example, the percent change in the thermistor resistance per minute for selected charge rates are provided. For selected charge rates greater than C/2, the thermistor resistance must decrease 4%/min. to terminate charge. For selected charge rates at or between C/2 and C/3, the thermistor resistance must decrease 3%/min. to terminate charge. For selected charge rates less than C/3, the thermistor must decrease 2%/min. to terminate charge.



For example, a battery was monitored as it charged at a 1C rate in 25°C ambient. In the final minute of charge, the battery temperature rose from 29.8°C to 31°C where full charge was detected. With this data, the typical 10kΩ @ 25°C thermistor used in the example above is checked to determine if its characteristics satisfy the 4% decrease in resistance required for the last minute of charge. The thermistor measures 8.37kΩ @ 29.8°C and 8.01kΩ at 31°C. For a 1C charge rate, the resistance must decrease at least 4%/min. or more between 29.8°C and 31°C. The percent decrease in resistance for the thermistor is calculated as:

$$\frac{8.37k\Omega - 8.01k\Omega}{8.37k\Omega} (100) = 4.30\%$$

This thermistor meets the 4%/min. requirement and will result in termination at full charge at 31°C. The thermistor must be checked for a 4%/min. decrease in resistance for the last minute of charge near the hot and cold battery thresholds.

The battery in the example above was charged in a 25°C ambient with its temperature rising 31°C - 25°C or 6°C. The temperature rise was 31°C - 29.8°C or 1.2°C in the last minute before full charge occurred. This information is used to check the thermistor characteristics at the ambient extremes. If the selected 1C charge rate is initiated at 12°C, the thermistor resistance change must decrease 4%/min. between 16.8°C and 18°C. The thermistor resistance at 16.8°C is 13.68kΩ and at 18°C the thermistor resistance is 13.06kΩ.

$$\frac{13.68k\Omega - 13.06k\Omega}{13.68k\Omega} (100) = 4.53\%$$

The thermistor meets the 4%/min. requirement and will result in termination of fast charge at 18°C. If the selected 1C charge rate is initiated at 37°C, the thermistor resistance change must decrease 4%/min. between 41.8°C and 43°C. The thermistor resistance at 41.8°C is 5.48kΩ and at 43°C the thermistor resistance is 5.25kΩ.

$$\frac{5.48k\Omega - 5.25k\Omega}{5.48k\Omega} (100) = 4.19\%$$

The thermistor meets the 4%/min. requirement and will result in termination of fast charge at 43°C.

The 4%/min., 3%/min. and 2%/min. decrease in thermistor resistance for the last minute of charge for the selected charge rate are applicable for NTC thermistors other than 10kΩ @ 25°C provided that the following requirements are met:

- An external pull-up resistor to 5V is used to provide a
- thermistor voltage of 1.67V @ 25°C.
- The thermistor resistance at 25°C does not exceed 20kΩ so that accuracy and adequate noise immunity are maintained.
- The thermistor resistance increases by a factor of about 1.8 from 25°C to 10°C and the thermistor resistance decreases by a factor of about 2.1 from 25°C to 45°C.
- Using a thermal switch for hot battery detection:

A thermal switch that opens at about 45°C is recommended. The thermal switch must be connected between the THERM pin and ground. When the thermal switch is closed, the voltage at the THERM pin must be below 0.5V for normal operation. When the thermal switch opens (see Figure 12), the internal pull-up at the THERM pin will raise the voltage above 4.2V and the ICS1702 will shut down and will not restart unless reset. Table 7 contains the internal voltage thresholds used with a thermal switch.

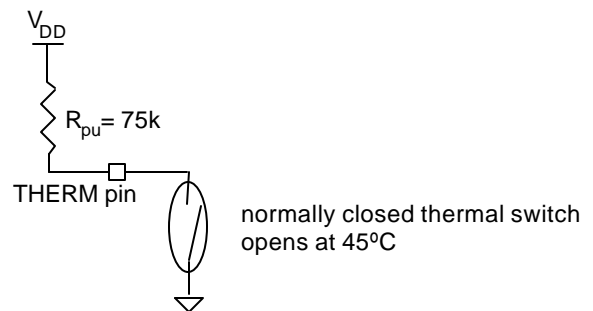

Figure 12: Thermal switch to connection to ground at the THERM pin

Table 7: Thermal Switch Voltage Thresholds

Parameter	Voltage	Battery Temperature
Open Thermal Switch Voltage	>4.2	>45°C
Closed Thermal Switch Voltage	<0.5	<45°C



ICS1702

•Using no temperature sensor:
If a temperature sensor is not used, the THERM pin must be grounded.

Termination Selection: DTSEL Pin

The ICS1702 has the capability of either temperature slope termination, voltage slope termination or both methods simultaneously. The DTSEL pin has an internal 75kΩ pull-down resistor that enables voltage slope termination as the primary method and is the default condition. Tying the pin high enables both temperature slope and voltage slope termination methods. Temperature slope termination as the primary method is enabled by tying the DTSEL pin to the CMN output (pin 5). CMN must have an external 15kΩ or lower value pull-up resistor to V_{DD} for proper activation of temperature slope termination. The ICS1702 must be reset if a new termination method is desired. Table 8 summarizes the DTSEL pin settings. NOTE: Maximum temperature and fast charge timer termination methods are always enabled when using temperature slope termination. Refer to the sections on *Fast Charge Timer Termination* and *Maximum Temperature Termination* for more information.

Table 8: Termination Select List

Tie DTSEL Pin to ...	Result
Low (No Connect)	Voltage slope termination only
High	Voltage slope and temperature slope termination
CMN	Temperature slope termination only (CMN with external pull-up to V _{DD})

Voltage Input: VIN Pin

The battery voltage must be normalized by an external resistor divider network to one cell. The electrochemical potential of one cell is about 1.2V. For example, if the battery consists of six cells in series, the voltage at the VIN pin must be equal to the total battery voltage divided by six. This can be accomplished with two resistors, as shown in Figure 13. To determine the correct resistor values, count the number of cells to be charged in series. Then choose either R1 or R2 and solve for the other resistor using:

$$R1 = R2 * (\# \text{ of cells} - 1) \text{ or } R2 = \frac{R1}{(\# \text{ of cells} - 1)}$$

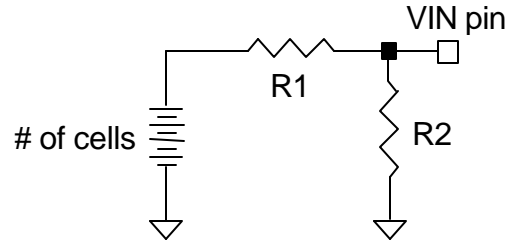

Figure 13: Resistor divider network at the VIN pin

Open Circuit Voltage Reference: OPREF Pin

The OPREF pin requires an external resistor divider to establish the open circuit (no battery) voltage reference. The purpose of this voltage reference is to detect the removal of the battery from the charging system. The voltage at this pin is compared to the voltage at the VIN pin when the current source is turned on. If the voltage at VIN is greater than the voltage at OPREF, the ICS1702 assumes the battery has been removed and the ICS1702 enters the polling detect mode.

For proper operation, the voltage at OPREF must be set between the (divided down) open circuit voltage produced by the current source and the maximum normalized battery voltage. An example is shown in Figure 14.

Suppose that a current source has an open circuit voltage of 12V. The maximum expected battery voltage of a six-cell pack is determined to be 9.6V. The voltage at OPREF should be set at a point between 1.6V (9.6V/6 cells=1.6V) and 2V (12V/6=2V). This is accomplished with a resistor divider network. In this example, R4 and R3 are referred to V_{DD}. Refer to the VIN and OPREF divider resistor tables in the *Applications Information* section.

From the VIN table, the divider resistors are 10kΩ and 2kΩ for R1 and R2. From the OPREF table, the divider resistors are 2.2kΩ and 1.3kΩ for R3 and R4. If R3 is 2.2kΩ and R4 is 1.3kΩ, the voltage at OPREF is 1.86V.

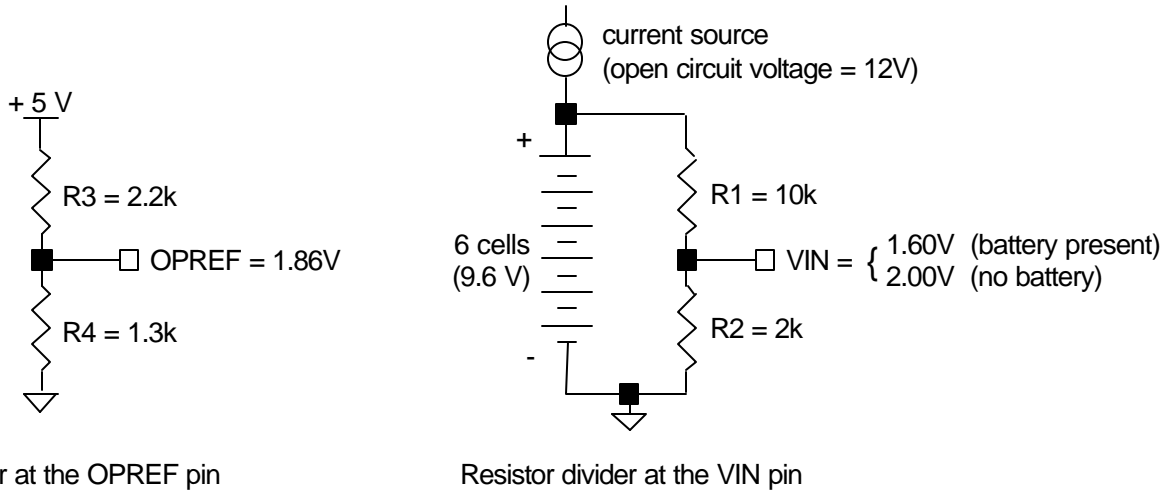

Figure 14: Open Circuit Reference Example

Power: VDD Pin

The power supply for the device must be connected to the VDD pin. The voltage should be +5 VDC and should be supplied to the part through a regulator that has good noise rejection and an adequate current rating. The controller requires up to a maximum of 11mA with VDD=5.00V.

Grounding: VSS, AVSS Pins

There are two ground pins. Both pins must be connected together at the device. This point must have a direct connection to a solid ground plane.

Data Tables

Table 9: Absolute Maximum Ratings

Supply Voltage	6.5	V
Logic Input Levels	-0.5 to V _{DD} + 0.5	V
Ambient Operating Temperature	0 to 70	°C
Storage Temperature	-55 to 150	°C

Stresses above those listed under Absolute Maximum Ratings may cause permanent damage to the device. This is a stress rating only. Functional operation of the device at the Absolute Maximum Ratings or other conditions not consistent with the characteristics shown in this document is not recommended. Exposure to absolute maximum rating conditions for extended periods may affect product reliability.



Table 10: DC Characteristics

$T_{amb}=25^{\circ}\text{C}$. All values given are typical at specified V_{DD} .

Parameter	Symbol	Test Conditions	MIN	TYP	MAX	UNITS
Supply Voltage	V_{DD}		4.5	5.0	5.5	V
Supply Current	I_{DD}			7.3		mA
High Level Input Voltage SEL0, SEL1, AUX0, AUX1	V_{IH}		3.6	4.1	4.5	V
Low Level Input Voltage SEL0, SEL1, AUX0, AUX1	V_{IL}		0.73	0.75	0.8	V
Open Input Voltage SEL0, SEL1, AUX0, AUX1		open		2.3		V
Low Level Input Current, pull-up THERM, MRN	I_{IL}	$V=0.4\text{V}$		74		μA
High Level Input Current, pull-down THERM, MRN	I_{IH}	$V=V_{DD} - 0.4\text{V}$		75		μA
High Level Source Current CHG, DCHG	I_{OH}	$V=V_{DD} - 0.4\text{V}$		28		mA
Low Level Sink Current CHG, DCHG	I_{OL}	$V=0.4\text{V}$		25		mA
Low Level Sink Current, indicator PFN, CMN, MMN	I_{OL}	$V=0.4\text{V}$		40		mA
Low Level Sink Current, indicator OTN	I_{OL}	$V=0.4\text{V}$		28		mA
Input Impedance				1.0		$\text{M}\Omega$
Analog/Digital Converter Range			0-2.2	0-2.7	0-2.7	V

Table 11: DC Voltage Thresholds

$T_{AMB}=25^{\circ}\text{C}$

PARAMETER	TYP	UNITS
Minimum Battery Voltage	0.5	V
Thermistor - Cold Temperature	2.4	V
Thermistor - Hot Temperature	0.93	V
Thermal Switch - Open	4.2	V
Thermal Switch - Closed	0.5	V



Table 12: Timing Characteristics

R≈16kΩ, C≈100pF

PARAMETER	SYMBOL	REFERENCE	TYP	UNITS
Clock Frequency			1.0	MHz
Reset Pulse Duration	t_{RESET}	see Figure B	700	ms
Charge Pulse Width	t_{CHG}	see Figure A	1048	ms
Discharge Pulse Width	t_{DCHG}	see Figure A	5.0	ms
Rest Time	t_R	see Figure A	4.0	ms
Data Acquisition Time	t_{DA}	see Figure A	16.4	ms
Cycle Time	t_{CYCLE}	see Figure A	1077	ms
Capacitor Discharge Pulse Width			5.0	ms
Capacitor Discharge Pulse Period			100	ms
Polling Detect Pulse Width			100	ms
Polling Detect Pulse Period			624	ms
Soft Start Initial Pulse Width			200	ms
Soft Start Incremental Pulse Width			7.0	ms
Discharge Mode Pulse Width			400	ms
Discharge Mode Pulse Period			1050	ms
RESET to SEL Dynamic Reprogram Period	t_{RSA}	see Figure B	1160	ms
RESET to AUX Dynamic Reprogram Period	t_{RSA}	see Figure B	1160	ms

Timing Diagrams

Figure A:

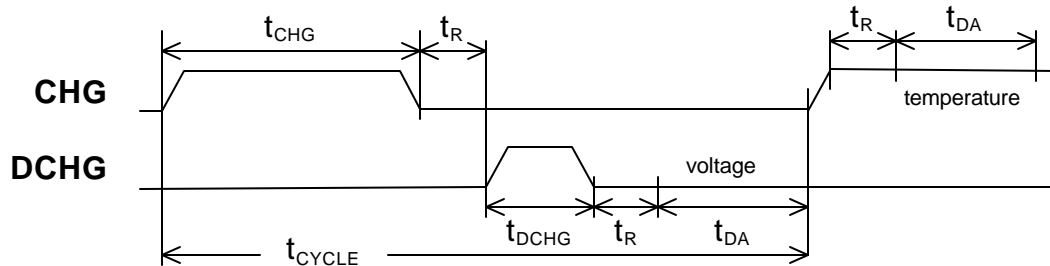
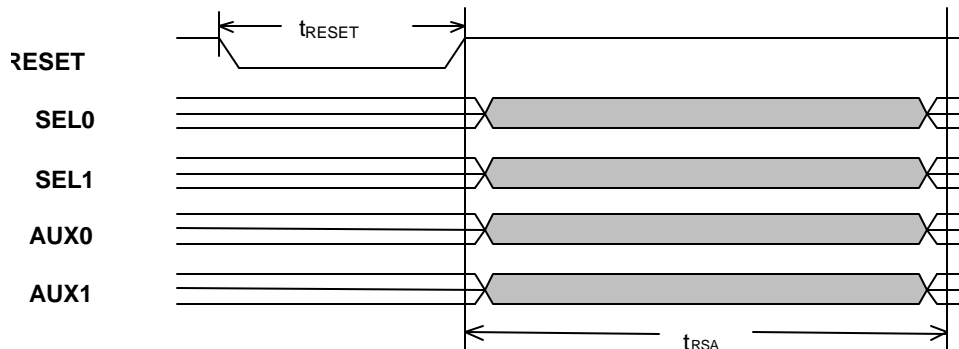

Figure B:





Applications Information

To ensure proper operation of the **ICS1702**, external components must be properly selected. The external current source used must meet several important criteria to ensure optimal performance of the charging system. The charging current should be constant when using voltage slope termination. The current may vary when using temperature slope termination.

VIN and OPREF Divider Resistors

Figure 15 shows a typical application using the **ICS1702**. R1 through R4 must be carefully selected to ensure that battery detection and voltage termination methods operate properly.

R1 and R2 are selected to scale the battery voltage down to the voltage of one cell. The following table shows some typical values. Additional information is available in the *Voltage Input* section.

Cells	R1	R2
1	Short	Open
2	2.0k	2.0k
3	2.0k	1.0k
4	3.0k	1.0k
5	12k	3.0k
6	10k	2.0k
7	12k	2.0k
8	9.1k	1.3k

If using voltage slope termination, the current source should prevent ripple voltage from appearing on the battery. The effects of ripple on the battery voltage may interfere with proper operation when using the voltage slope method.

R3 and R4 are used to set the open circuit (no battery) reference voltage on the OPREF pin. The function of this pin is discussed in the *Open Circuit Reference* section.

V _{OPREF}	R3	R4
1.86 V	2.2k	1.3k
1.92 V	2.4k	1.5k
1.97 V	2.0k	1.3k
2.00 V	3.0k	2.0k
2.03 V	2.2k	1.5k
2.10 V	1.8k	1.3k
2.14 V	2.4k	1.8k
2.22 V	3.0k	2.4k

With the batteries removed, the current source must be capable of raising the voltage at the VIN pin above the voltage at the OPREF pin to ensure proper polling. With the batteries installed, the current source overshoot characteristics when turned on and off must not cause the voltage at the VIN pin to exceed the voltage at the OPREF pin. If the voltage at OPREF exceeds the voltage at VIN when a charge pulse is applied or removed, the polling feature will be activated.

PC Board Design Considerations

It is very important that care be taken to minimize noise coupling and ground bounce. In addition, wires and connectors can add significant resistance and inductance to the charge and discharge circuits. When designing the printed circuit board, make sure ground and power traces are wide and bypass capacitors are used right at the controller. Use separate grounds for the signal, charge and discharge circuits. Separate ground planes on the component side of the PC board are recommended. Be sure to connect these grounds together at the negative lead of the battery only. For the discharge circuit, keep the physical separation between power and return (ground) to a minimum to minimize field radiation effects. This precaution is also applicable to the constant current source, particularly if it is a switch mode type. Keep the **ICS1702** and the constant current source control circuits outside the power and return loop described above. These precautions will prevent high circulating currents and coupled noise from disturbing normal operation.

Selecting the Appropriate Termination Method

In general, the voltage slope termination method works best for equipment where the battery is fast charged with the equipment off or the battery is removed from the equipment for fast charge. The temperature slope and maximum temperature termination methods are for equipment that must remain operative while the battery is fast charged.



•Voltage Slope Termination

The voltage slope termination method used by the **ICS1702** requires a nearly constant current flow into the battery during fast charge. Equipment that draws a known constant current while the battery is charging may use the voltage slope termination method. This constant current draw must be added to the fast charge current. Using the voltage slope termination method for equipment that randomly or periodically requires moderate current from the battery during fast charge needs evaluation. Equipment that randomly or periodically requires high current from the battery during fast charge may cause a voltage inflection that results in termination before full charge. A voltage inflection can occur due to the charge current decreasing or fluctuating as the load changes rather than by the battery reaching full charge. The voltage slope method will terminate charge based on voltage inflections that are characteristic of a fully charged battery.

Charging sources that produce decreasing current as fast charge progresses may also cause a voltage inflection that may result in termination before full charge. For example, if the charge current is supplied through a resistor or if the charging source is a constant current type that has insufficient input voltage, the current will decrease and may cause a termination before full charge. Other current source abnormalities that may cause a voltage inflection that is characteristic of a fully charged battery are inadequate ripple and noise attenuation capability or charge current decreasing due to thermal drift. Charging sources that have any of the above characteristics need evaluation to assess their suitability for the application if the use of the voltage slope termination is desired.

When using voltage slope termination, the controller soft start stage, built-in noise filtering, and fast charge timer operate optimally when the constant current source charges the battery at the rate selected. If the actual charge current is significantly less than the rate selected, the conditioning effect of the soft start stage and the controller noise immunity are lessened. Also, the fast charge timer may cause termination based on time duration rather than by the battery reaching full charge due to inadequate charge current.

•Temperature Slope and Maximum Temperature

Temperature slope and/or maximum temperature termination may have to be used for equipment that has high dynamic current demands while operating from the battery during fast charge. Also, users who do not have a well regulated constant current source available may have to use temperature termination. In general, utilizing temperature slope as the primary termination method with maximum temperature termination as a safety back-up feature is the best approach. When using temperature slope termination, the actual current should not be appreciably lower than the selected rate in order that termination of fast charge occurs due to the battery reaching full charge rather than by the timer expiring.

Temperature termination methods require that the thermal sensor be in intimate contact with the battery. A low thermal impedance contact area is required for accurate temperature sensing. The area and quality of the contact surface between the sensor and the battery directly affects the accuracy of temperature sensing. Thermally conductive adhesives may have to be considered in some applications to ensure good thermal transfer from the battery case to the sensor.

The thermal sensor should be placed on the largest surface of the battery for the best accuracy. The size of the battery is also a consideration when using temperature termination. The larger the battery the lower the surface area to volume ratio. Because of this, larger batteries are less capable in dissipating internal heat.

Additional considerations beyond the basics mentioned above may be involved when using temperature slope termination where sudden changes in ambient temperature occur or where forced air cooling is used. For these applications, the surface area of the thermal sensor in contact with the battery compared to the surface area of the thermal sensor in contact with the ambient air may be significant. For example, bead type thermistors are relatively small devices which have far less thermal capacity compared to most batteries. Insulating the surface of the thermistor that is in contact with the ambient air should help minimize heat loss by the thermistor and maintain accuracy.



ICS1702

Charging System Status by Indicator

The *Indicator Description List* in Table 3 contains displays that are caused by charging system abnormalities. When the CMN indicator is flashing with no other indicator active, there is voltage present at the battery terminals with the current source off and no battery. Check the current source and ensure that it produces no more than the equivalent of 350mV/cell when turned off with no battery. If the VIN divider resistors were not properly selected, an open circuit voltage that is actually less than the equivalent of 350mV/cell with the charger off and no battery will not divide down this open circuit voltage properly and produce the CMN flash indication. Check the VIN divider and ensure that it properly normalizes the battery voltage to the electrochemical potential of about 1.2V cell. If the CMN flash indication occurs with the battery installed, then the constant current source is producing more than the equivalent of 350mV/cell when off and there is an open connection between the charger terminals and the battery. Check wires, connections, battery terminals, and the battery itself for an open circuit condition.

If the CMN and OTN indicators are active together, this is an indication that the battery temperature has dropped to below 10°C after a fast charge was initiated with the battery temperature normal. If this condition is observed and the battery temperature did not drop after high charge was initiated, check the thermistor circuit mechanically for poor contact and electrically for excessive noise.

If the MMN and CMN indicators are alternately flashing, the likely cause is no battery with the **ICS1702** programmed in the discharge-to-charge auxiliary mode. If the battery is present, check wires, connectors, battery terminals, and the battery itself for an open circuit condition.

If the MMN indicator is flashing with the OTN indicator active, this is an indication that the battery is cold while in either the discharge portion of the discharge-to-charge mode or the discharge only mode. When in the discharge-to-charge mode, if the battery does not warm-up into the normal temperature range after the discharge is complete, the **ICS1702** will enter the maintenance charge stage. When the battery warms-up, the discharge-to-charge mode will repeat.



ICS1702

Package Information

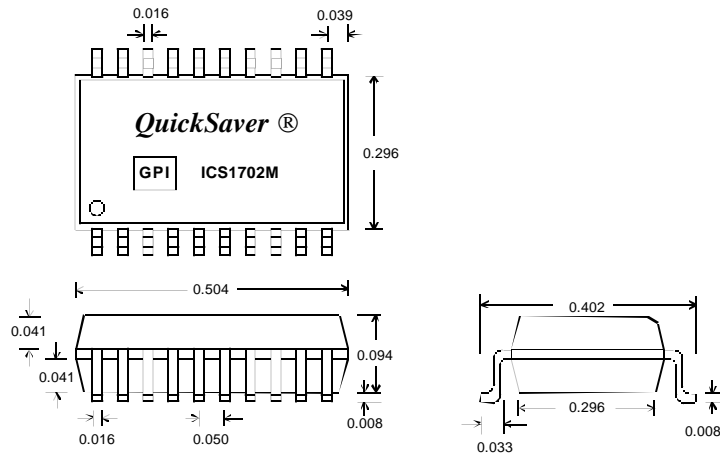

All package dimensions are in inches.

20-Pin SOIC Package (300 mil)

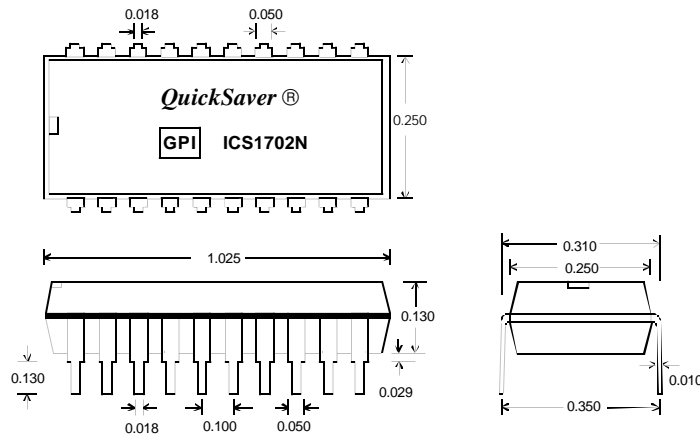

All package dimensions are in inches.

20-Pin DIP Package (300 mil)

Ordering Information

ICS1702N, ICS1702M, ICS1702MT

Example:

ICS 1702 ST

Package type:

- N= DIP (Plastic)
- M= 300 mil SOIC
- MT= 300 mil SOIC Tape and Reel

Device type: Consists of 3 to 5 digits or numbers

Prefix: ICS = Intelligent Charging Solution standard device



IMPORTANT NOTICE

Galaxy Power Incorporated makes no claim about the capability of any particular battery (NiCd or NiMH) to accept a fast charge. GPI strongly recommends that the battery manufacturer be consulted before fast charging. GPI shall be held harmless for any misapplication of this device such as: exceeding the rated specifications of the battery manufacturer; charging batteries other than nickel-cadmium or nickel-metal hydride type; personal or product damage caused by the charging device, circuit, or system itself; unsafe use, application, and/or manufacture of a charging system using this device.

GPI reserves the right to make changes in the device data identified in this publication without further notice. GPI advises its customers to obtain the latest version of all device data to verify that any information being relied upon by the customer is current and accurate.

GPI does not assume any liability arising out of or associated with the application or use of any product or integrated circuit or component described herein. GPI does not convey any license under its patent rights or the patent rights of others described herein. In the absence of a written or prior stated agreement to the contrary, the terms and conditions stated on the back of the GPI order acknowledgment obtain.

GPI makes no warranty of any kind with regard to this material, including, but not limited to, the implied warranties of merchantability and fitness for a particular purpose.

GPI products are not designed, intended, or authorized for use as components in systems intended for surgical implant into the body, or other applications intended to support or sustain life, or for any nuclear facility application, or for any other application in which the failure of the GPI product(s) could create a situation where personal injury or death may occur. GPI will not knowingly sell its products for use in such applications, and the buyer shall indemnify and hold harmless GPI and its officers, employees, subsidiaries, affiliates, representatives and distributors against all claims, costs, damages, expenses, tort and attorney fees arising out of directly or indirectly, any claim of personal injury or death associated with such unintended or unauthorized use, even if such claim alleges that GPI was negligent regarding the design or manufacture of the part.

COPYRIGHT © 1998 Galaxy Power Incorporated



ICS1702

NOTES



NOTES

ICS1702

ICS1702



GPI Sales Offices

Headquarters

Galaxy Power, Inc.

PO Box 890

2500 Eisenhower Avenue

Valley Forge, PA 19482-0890

Phone: 1-610-676-0188

FAX: 1-610-676-0189

Internet: www.galaxypower.com

January 19, 1999

GPI Sales Representative
